



**SAFEMASTER**  
**Emergency Stop Module**  
**BD 5935**

**Translation**  
**of the original instructions**

**0262842**



**E. Dold & Söhne GmbH & Co. KG**  
 Bregstraße 18 • 78120 Furtwangen • Germany  
 Phone: +49 7723 654-0 • Fax +49 7723 654356  
 dold-relays@dold.com • www.dold.com

# Contents

Symbol and Notes Statement.....	13
General Notes .....	13
Designated Use .....	13
Safety Notes .....	13
Product Description .....	15
Function Diagram .....	15
Block Diagram .....	15
Approvals and Markings .....	15
Applications .....	15
Indication .....	15
Circuit Diagrams .....	16
Connection Terminals .....	16
Notes .....	16
Technical Data .....	17
Technical Data .....	17
CCC-Data .....	17
Standard Type.....	17
Variants.....	18
Troubleshooting .....	18
Maintenance and repairs .....	18
Characteristics.....	18
Application Example .....	18
Application Examples .....	19
Connection Technology .....	31
Dimensions (dimensions in mm) .....	31
Setting .....	31
Mounting / disassembly of the terminal strip .....	31
Safety Related Data .....	32
CE-Declaration of Conformity.....	33
UK Declaration of Conformity .....	34
Notice .....	35



Before installing, operating or maintaining this device, these instructions must be carefully read and understood.



Keep instructions for future reference



The installation must only be done by a qualified electrician!



Do not dispose of household garbage!  
The device must be disposed of in compliance with nationally applicable rules and requirements.

To help you understand and find specific text passages and notes in the operating instructions, we have important information and information marked with symbols.

### Symbol and Notes Statement



**DANGER:**  
Indicates that death or severe personal injury will result if proper precautions are not taken.



**WARNING:**  
Indicates that death or severe personal injury can result if proper precautions are not taken.



**CAUTION:**  
Indicates that a minor personal injury can result if proper precautions are not taken.



**INFO:**  
Referred information to help you make best use of the product.



**ATTENTION:**  
Warns against actions that can cause damage or malfunction of the device, the device environment or the hardware / software result.

### General Notes

The product hereby described was developed to perform safety functions as a part of a whole installation or machine. A complete safety system normally includes sensors, evaluation units, signals and logical modules for safe disconnections. The manufacturer of the installation or machine is responsible for ensuring proper functioning of the whole system. DOLD cannot guarantee all the specifications of an installation or machine that was not designed by DOLD. The total concept of the control system into which the device is integrated must be validated by the user. DOLD also takes over no liability for recommendations which are given or implied in the following description. The following description implies no modification of the general DOLD terms of delivery, warranty or liability claims.

### Designated Use

The BD 5935 is used to interrupt a safety circuit in a safe way. It can be used to protect people and machines in applications with e-stop buttons and safety gates.

When used in accordance with its intended purpose and following these operating instructions, this device presents no known residual risks. Nonobservance may lead to personal injuries and damages to property.

### Safety Notes



#### **Risk of electrocution!** **Danger to life or risk of serious injuries.**

- Disconnect the system and device from the power supply and ensure they remain disconnected during electrical installation.
- The device may only be used for the applications described in the mutually applicable operating instructions / data sheet. The notes in the respective documentation must be heeded. The permissible ambient conditions must be observed.
- The contact protection of the elements connected and the insulation of the supply cables must be designed in accordance with the requirements in the operating instructions / data sheet.
- Note the VDE and local regulations, particularly those related to protective measures.



#### **Risk of fire or other thermal hazards!** **Danger to life, risk of serious injuries or property damage.**

- The device may only be used for the applications described in the mutually applicable operating instructions / data sheet. The notes in the respective documentation must be heeded. The permissible ambient conditions must be observed. In particular, the current limit curve must be heeded.
- The device may only be installed and put into operation by experts who are familiar with this technical documentation and the applicable health and safety and accident prevention regulations.



#### **Functional error!** **Danger to life, risk of serious injuries or property damage.**

- The device may only be used for the applications described in the mutually applicable operating instructions / data sheet. The notes in the respective documentation must be heeded. The permissible ambient conditions must be observed.
- The device may only be installed and put into operation by experts who are familiar with this technical documentation and the applicable health and safety and accident prevention regulations.
- The unit should be panel mounted in an enclosure rated at IP 54 or superior. Dust and dampness may lead to malfunction.



#### **Installation fault!** **Danger to life, risk of serious injuries or property damage.**

- Make sure of sufficient protection circuitry at all output contacts for capacitive and inductive loads.



#### **Attention!**

- The safety function must be triggered during commissioning.
- **AUTOMATIC START !**  
According to IEC/EN 60 204-1 part 9.2.5.4.2 and 10.8.3 it is not allowed to restart automatically after emergency stop. Therefore the machine control has to disable the automatic start after emergency stop.
- Opening the device or implementing unauthorized changes voids any warranty



## SAFEMASTER Emergency Stop Module BD 5935

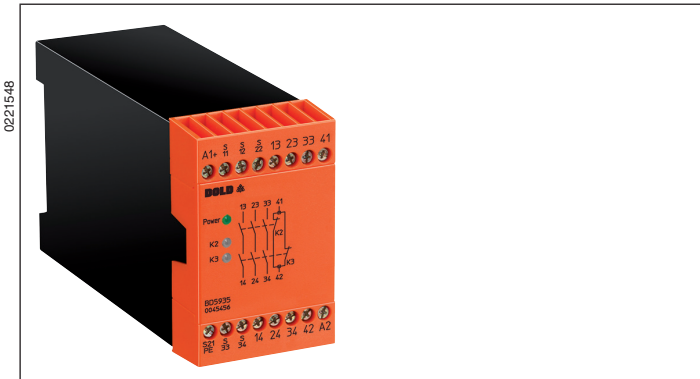

### Your Advantages

- Safe disconnection of electrical circuits
- Line fault detection on ON pushbutton
- Gold plated contacts to switch low loads (signal to PLC)
- Optionally cross fault detection in emergency stop circuit
- Easy exchange of devices by removable terminal strips

### Features

- **According to**
  - **Performance Level (PL) e and category 4 to EN ISO 13849-1**
  - **SIL Claimed Level (SIL CL) 3 to IEC/EN 62061**
  - **Safety Integrity Level (SIL 3) to IEC/EN 61508**
- 1- or 2-channel connection
- Operating state display
- LED display for channels 1 and 2
- Overvoltage and short circuit protection
- Wire connection: Also 2 x 1.5 mm<sup>2</sup> stranded ferruled (isolated), DIN 46228-1/-2/-3/-4 or 2 x 2.5 mm<sup>2</sup> stranded ferruled DIN 46228-1/-2/-3
- Output: Optionally 1 NO / 1 NC or 3 NO / 1 NC contacts
- Optionally automatic ON function or activation via the ON pushbutton
- With fast auto start as option
- Width 45 mm

### Product Description

The BD 5935 is used to interrupt a safety circuit in a safe way. It can be used to protect people and machines in applications with e-stop buttons and safety gates.

### Function Diagram

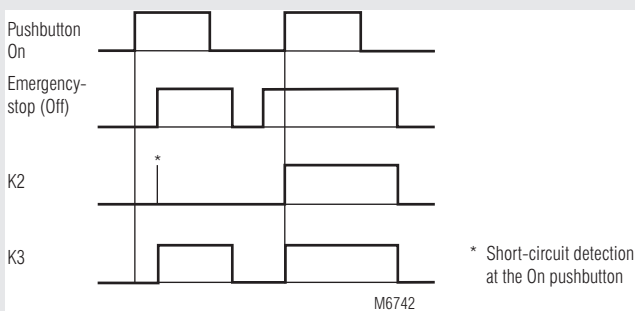

### Block Diagram

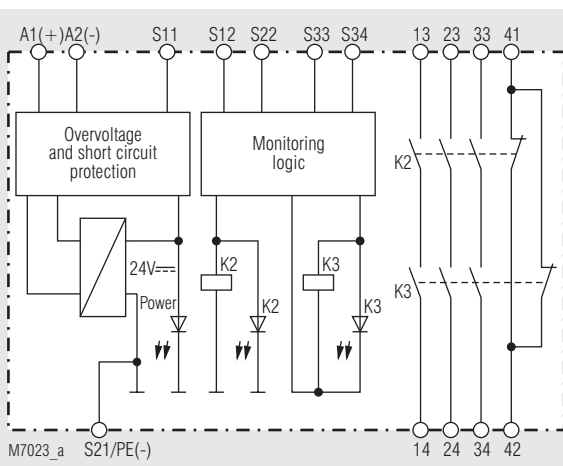

### Approvals and Markings



\* see variants

### Applications

- Protection of persons and machines
- Emergency-stop circuits on machines
  - Monitoring of safety gates

### Indication

- Upper LED: On when supply voltage connected  
Lower LEDs: On when relay K2 and K3 active

## Circuit Diagrams

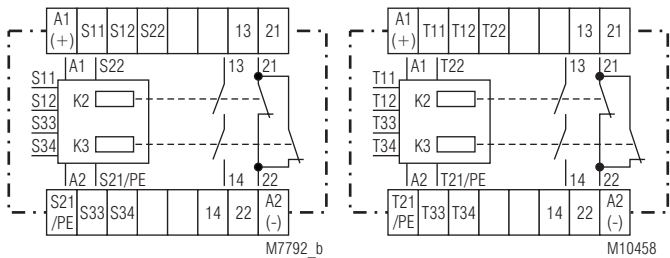

BD 5935.16

BD 5935.16/200

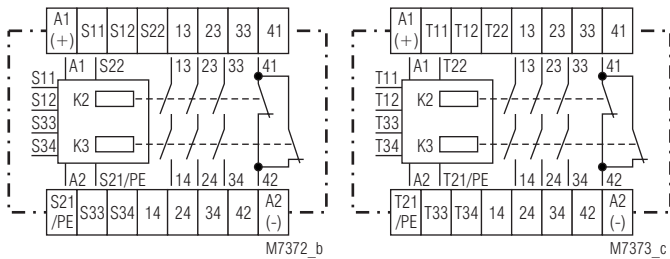

BD 5935.48

BD 5935.48/200

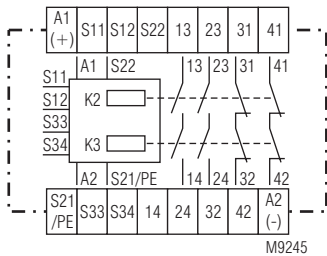

BD 5935.52

## Notes

If the ON pushbutton was already closed before the voltage was applied at S12, S22 (also in the case of line fault via the ON pushbutton), the output contacts cannot be switched on.

A line fault at the ON pushbutton which occurred after activation of the unit is recognized when switching on takes place again and switching-on of the output contacts is prevented. If a line fault occurs at the ON pushbutton after the voltage has already been applied at S12 and S22, unwanted activation occurs because this line fault can not be distinguished from the regular switching-on function. The PE testing terminal allows the units to be also operated in IT networks with insulation monitoring. It also serves as a reference point for checking the control voltage and as a connection contact in the event of an emergency-stop with cross fault detection.

Because of the gold-plated contacts the BD 5935 can be used to switch small loads 1 mA ... 7 VA, 1 mW ... 7 W in the range of 0.1 ... 60 V, 1 ... 300 mA. The gold-plated contacts allow also to switch the maximum current but the gold plating will be burnt off. After that the contacts cannot be used any more to switch the small loads.

One or more extension modules BN 3081 or external contactors with forcibly guided contacts can be used to multiply the number of contacts of the emergency-stop module BD 5935.

The switches S1 and S2 are provided for the following selection possibilities: Automatic-start, manual-start and emergency-stop with or without cross fault detection. These switches are located behind the front cover panel (see unit programming diagrams).

Switch S2 is for selecting automatic or manual Start. In addition, terminals S33 and S34 must be jumpered for "automatic start function".

Selection of the operating mode with or without cross fault detection at the emergency-stop pushbutton is performed via the switch S1. The unit must be connected as shown in the application example.

## Connection Terminals

Terminal designation	Signal description
A1(+)	+ / L
A2 (-)	- / N
S12, S22, S33, S34, T12, T22, T33, T34	Inputs
S11, S21/PE, T11, T21/PE,	Outputs
13, 14, 23, 24, 33, 34	Forcibly guided NO contacts for release circuit
21, 22, 31, 32, 41, 42	Forcibly guided indicator output

## Technical Data

### Input

<b>Nominal voltage <math>U_N</math>:</b>	AC 24, 42, 48, 110, 115, 120, 127, 230, 240 V DC 24 V
<b>Voltage range:</b>	AC 0.85 ... 1.1 $U_N$
at 10% residual ripple:	DC 0.9 ... 1.2 $U_N$
at 48% residual ripple:	DC 0.8 ... 1.1 $U_N$
<b>Nominal consumption:</b>	AC approx. 4 VA, DC approx. 2 W
<b>Nominal frequency:</b>	50 / 60 Hz
<b>Recovery time:</b>	0.5 s after activating the emergency-stop button. If the line fault detection of the ON-button is active, the device must stay off for approx. 5 sec.
<b>Control voltage at S11:</b>	DC 22 V
<b>Control current via S12, S22:</b>	Approx. 35 mA $\pm$ 25 % at $U_N$
<b>Minimum voltage at terminal S12, S22:</b>	DC 21 V when unit is activated

### Output

<b>Contacts</b>	
BD 5935.16:	1 NO / 1 NC contacts
BD 5935.48:	3 NO / 1 NC contacts
BD 5935.52:	2 NO contacts / 2 NC contacts

The NO contacts are safety contacts.

**The NC contacts 21-22, 31-32 and 41-42 can only be used for monitoring.**

### Operate time

activation via ON pushbutton:	50 ms - 25 % + 50 %
automatic ON function:	1 s - 25 % + 50 %, as option also with shorter on-delay (see variants)

### Release time

at 2-channel disconnecting opening in secondary circuit (S12 and S22):	25 ms - 25 % + 50 %
at disconnecting in supply circuit:	50 ms - 25 % + 50 %

### Fault detection time at $U_N$

at 1-channel interruption at S12:	Typ. 290 ms
at S22:	25 ms - 25 % + 50 %

**Contact type:** Relay, forcibly guided

### Rated output voltage:

AC 250 V  
DC: See arc limit curve  
See quadratic total current limit curve (max. 10 A in one contact path)

### Thermal current $I_{th}$ :

### Switching capacity

to AC 15		
NO contact:	3 A / AC 250 V	IEC/EN 60947-5-1
NC contact:	2 A / AC 250 V	IEC/EN 60947-5-1
to AC 15		
NO contact:	6 A / AC 230 V at 0.25 Hz	
NC contact:	2 A / AC 230 V at 0.25 Hz	
to DC 13		
NO contact:	2 A / DC 24 V	IEC/EN 60947-5-1
NC contact:	2 A / DC 24 V	IEC/EN 60947-5-1
to DC 13		
NO contact:	6 A / DC 24 V at 0.1 Hz	
NC contact:	6 A / DC 24 V at 0.1 Hz	

### Electrical life

at AC 230 V, 6 A  $\cos \varphi = 1$ :  $> 5 \times 10^5$  switching cycles

### Permissible operating frequency:

600 switching cycles / h

### Short circuit strength

max. fuse rating:

NO contact:	10 A gG / gL	IEC/EN 60947-5-1
NC contact:	6 A gG / gL	IEC/EN 60947-5-1

### Mechanical life:

$10 \times 10^6$  switching cycles

## Technical Data

### General Data

<b>Operating mode:</b>	Continuous operation
<b>Temperature range</b>	
Operation:	- 15 ... + 55 °C at max. 90% humidity - 25 ... + 85 °C
Storage:	$\leq 2000$ m
<b>Altitude:</b>	
<b>Clearance and creepage distances</b>	
Rated impulse voltage / pollution degree:	4 kV / 2 (basis insulation) IEC 60664-1 IEC/EN 62 061
<b>EMC:</b>	
Interference suppression:	Limit value class B EN 55011
<b>Degree of protection:</b>	
Housing:	IP 40* IEC/EN 60529
Terminals:	IP 20 IEC/EN 60529
	* when front plate is removed to set switches, protection class IP 40 is not valid
<b>Housing:</b>	Thermoplastic with V0 behaviour according to UL subject 94
<b>Vibration resistance:</b>	Amplitude 0.35 mm IEC/EN 60068-2-6 frequency 10 ... 55 Hz
<b>Climate resistance:</b>	15 / 055 / 04 IEC/EN 60068-1
<b>Terminal designation:</b>	EN 50005
<b>Wire fixing:</b>	Plus-minus terminal screws M3.5, box terminal with wire protection
<b>Mounting:</b>	DIN rail IEC/EN 60715
<b>Weight:</b>	450 g

### Dimensions

<b>Width x height x depth:</b>	45 x 74 x 121 mm
--------------------------------	------------------

### CCC-Data

<b>Nominal voltage <math>U_N</math>:</b>	AC 24, 42, 48, 110, 115, 120, 127, 230 V DC 24 V
--	---

<b>Thermal current <math>I_{th}</math>:</b>	See quadratic total current limit curve (max. 5 A in one contact path)
---	--

### Switching capacity

to AC 15		
NO contact:	2 A / AC 230 V	IEC/EN 60947-5-1
to DC 13		
NO contact:	1 A / DC 24 V	IEC/EN 60947-5-1



Technical data that is not stated in the CCC-Data, can be found in the technical data section.

### Standard Type

BD 5935.48 DC 24 V	
Article number:	0045456
• Output:	3 NO / 1 NC contacts
• Nominal voltage $U_N$ :	DC 24 V
• Width:	45 mm



## Application Examples

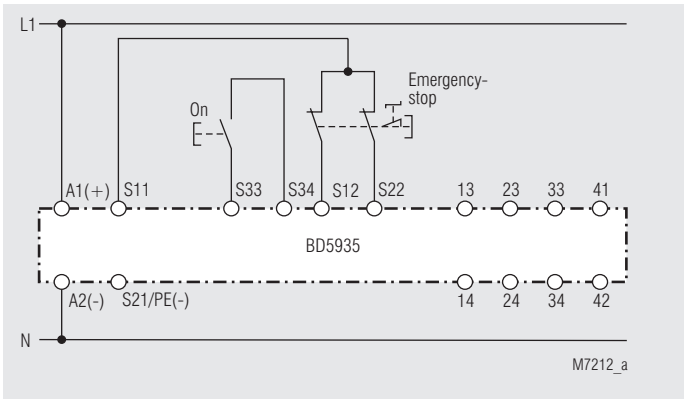

Two-channel emergency-stop circuit without cross fault detection.

**Please note "Unit programming" !**

Switches in pos.: S1 no cross fault detection  
S2 manual start

Suited up to SIL3, Performance Level e, Cat. 4

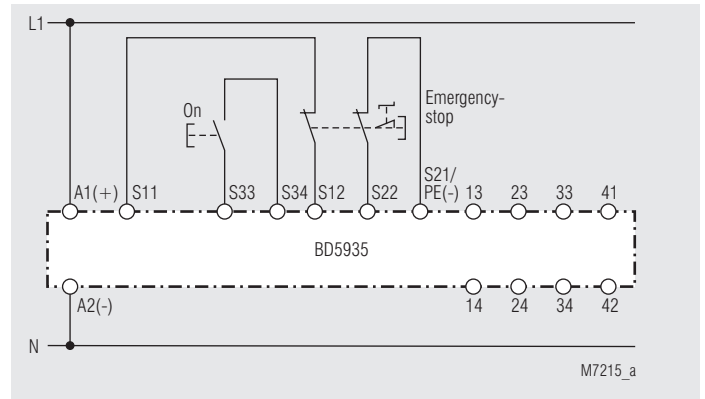

Two-channel emergency-stop circuit with cross fault detection.

**Please note "Unit programming" !**

Switches in pos.: S1 cross fault detection  
S2 manual start

Suited up to SIL3, Performance Level e, Cat. 4

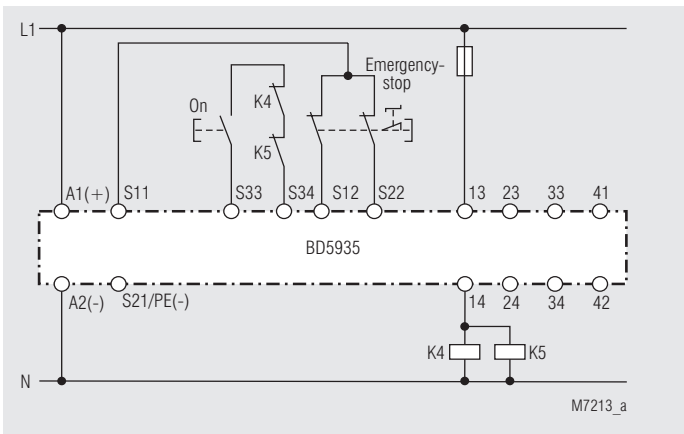

Contact reinforcement with external contactors, controlled with one contact path.

**Please note "Unit programming" !**

Switches in pos.: S1 no cross fault detection  
S2 manual start

Suited up to SIL3, Performance Level e, Cat. 4

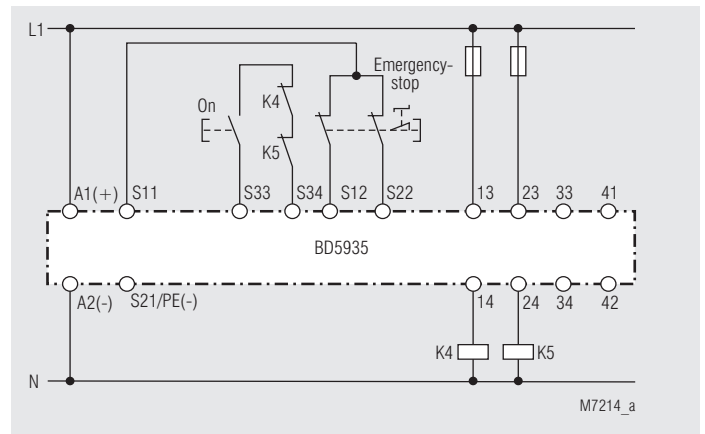

Contact reinforcement by external contactors, controlled with 2 contact paths. With switching current > 10 A, the output contacts can be reinforced by external contactors with forcibly guided contacts. The function of the external contactors is monitored by looping the NC contacts into the making circuit (terminals S33-S34).

**Please note "Unit programming" !**

Switches in pos.: S1 no cross fault detection  
S2 manual start

Suited up to SIL3, Performance Level e, Cat. 4

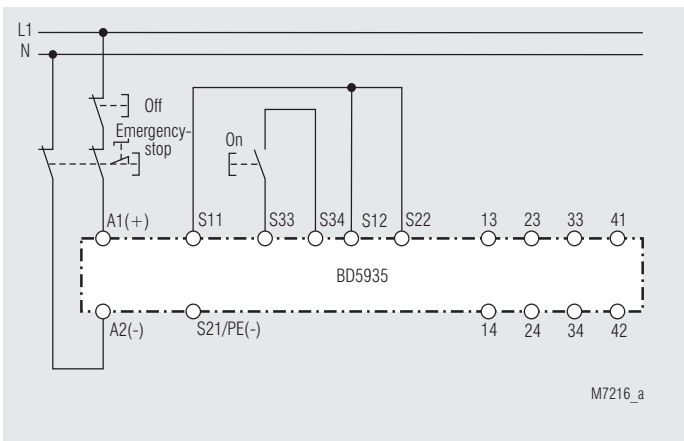

Two-pole emergency-stop with emergency-stop control device in the supply circuit.

Application for long emergency-stop loops in which the control voltage dropped below the minimum voltage of 21 V.

**Important:**

Single faults (line shorts over the emergency-stop control device) are not identified with this external circuit.

**Please note "Unit programming" !**

Switches in pos.: S1 no cross fault detection  
S2 manual start

Suited up to SIL3, Performance Level e, Cat. 4

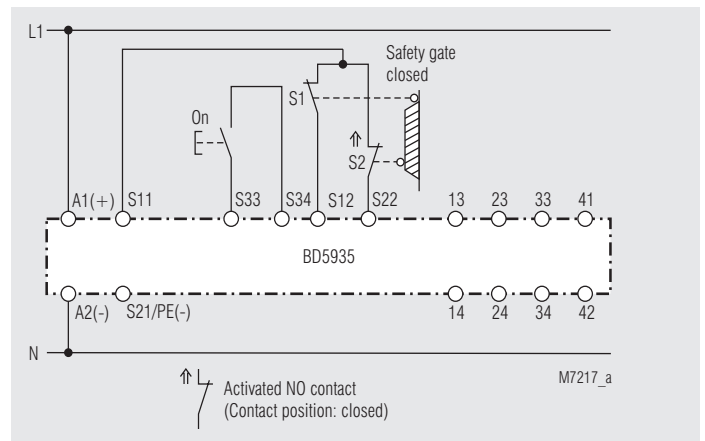

Two-channel monitoring of a safety gate.

The switch of S12 must close simultaneously with S22 or later.

**Please note "Unit programming" !**

Switches in pos.: S1 no cross fault detection  
S2 manual start

Suited up to SIL3, Performance Level e, Cat. 4



DE	<b>Anschlussstechnik</b>
EN	<b>Connection Technology</b>
FR	<b>Technologie de connexion</b>

DE	<b>Geräteprogrammierung</b>
EN	<b>Setting</b>
FR	<b>Programmation de l'appareil</b>

Klemmenleiste abnehmbar  
Removable terminal strip  
Borniers amovibles

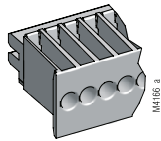

	ø 4 mm / PZ 1 0,8 Nm 7 LB. IN
	A = 10 mm 1 x 0,5 ... 4 mm <sup>2</sup> 1 x AWG 20 to 12 2 x 0,5 ... 1,5 mm <sup>2</sup> 2 x AWG 20 to 16
	A = 10 mm 1 x 0,5 ... 2,5 mm <sup>2</sup> 1 x AWG 20 to 14 2 x 0,5 ... 1,5 mm <sup>2</sup> 2 x AWG 20 to 16
	A = 10 mm 1 x 0,5 ... 4 mm <sup>2</sup> 1 x AWG 20 to 12 2 x 0,5 ... 1,5 mm <sup>2</sup> 2 x AWG 20 to 16

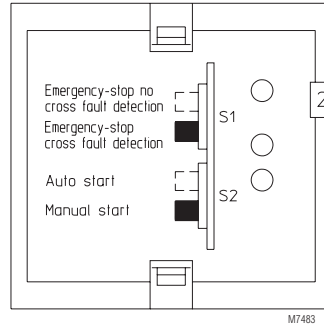
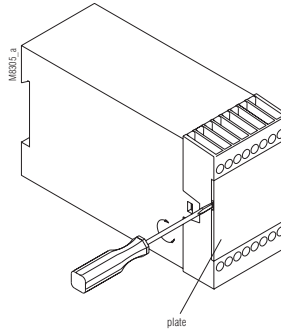

DE	S1 Querschlusserkennung <input type="checkbox"/> nicht sicher <input checked="" type="checkbox"/> sicher
FR	S1 Transversal <input type="checkbox"/> sans <input checked="" type="checkbox"/> avec
DE	S2 Start <input type="checkbox"/> Auto <input checked="" type="checkbox"/> Hand
FR	S2 Reset <input type="checkbox"/> Auto <input checked="" type="checkbox"/> Manu

DE	S1 darf nur bei unbestromtem Gerät betätigt werden! Die Schalterstellung zeigt den Lieferzustand.
EN	Disconnect unit before setting of S1 Drawing shows setting at the state of delivery
FR	Commutation de S1 uniquement hors tension. Appareil livré tel que sur le schéma.

DE	<b>Maßbild (Maße in mm)</b>
EN	<b>Dimensions (dimensions in mm)</b>
FR	<b>Dimensions (dimensions en mm)</b>

DE	<b>Montage / Demontage Klemmenleiste</b>
EN	<b>Mounting / disassembly of the terminal strip</b>
FR	<b>Montage / Démontage de bornier</b>

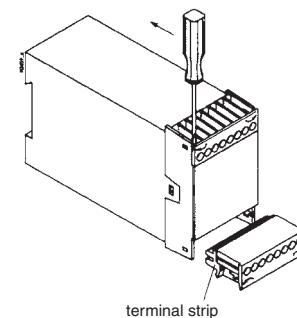
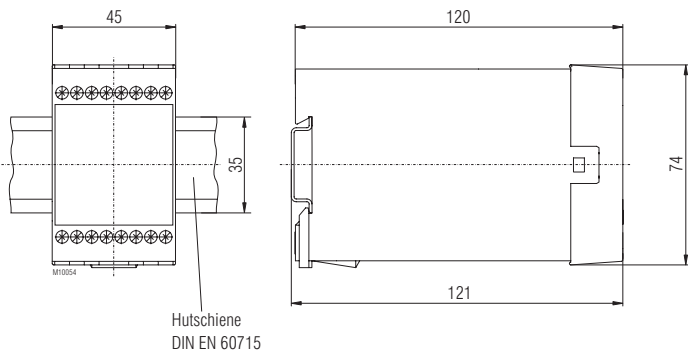

DE	<b>Sicherheitstechnische Kenndaten</b>
EN	<b>Safety Related Data</b>
FR	<b>Données techniques sécuritaires</b>

<b>EN ISO 13849-1:</b>		
Kategorie / Category:	4	
PL:	e	
MTTF <sub>d</sub> :	238,4	a (year)
DC <sub>avg</sub> :	99,0	%
d <sub>op</sub> :	365	d/a (days/year)
h <sub>op</sub> :	24	h/d (hours/day)
t <sub>cycle</sub> :	3600	s/cycle
	≅ 1	/h (hour)

<b>IEC/EN 62061 IEC/EN 61508:</b>		
SIL CL:	3	IEC/EN 62061
SIL	3	IEC/EN 61508
HFT <sup>1)</sup> :	1	
DC:	99,0	%
PFH <sub>D</sub> :	1,95E-10	h <sup>-1</sup>
<sup>1)</sup> HFT = Hardware-Fehlertoleranz Hardware failure tolerance Tolérance défauts Hardware		

Anforderung seitens der Sicherheitsfunktion an das Gerät		Intervall für zyklische Überprüfung der Sicherheitsfunktion
Demand to our device based on the evaluated necessary safety level of the application.		Intervall for cyclic test of the safety function
Consigne résultant de la fonction sécuritaire de l'appareil		Interval du contrôle cyclique de la fonction sécuritaire
nach, acc. to, selon EN ISO 13849-1	PL e with Cat. 3 or Cat. 4	einmal pro Monat once per month mensuel
	PL d with Cat. 3	einmal pro Jahr once per year annuel
nach, acc. to, selon IEC/EN 62061, IEC/EN 61508	SIL CL 3, SIL 3 with HFT = 1	einmal pro Monat once per month mensuel
	SIL CL 2, SIL 2 with HFT = 1	einmal pro Jahr once per year annuel



DE	Die angeführten Kenndaten gelten für die Standardtype. Sicherheitstechnische Kenndaten für andere Geräteausführungen erhalten Sie auf Anfrage. Die sicherheitstechnischen Kenndaten der kompletten Anlage müssen vom Anwender bestimmt werden.
EN	The values stated above are valid for the standard type. Safety data for other variants are available on request. The safety relevant data of the complete system has to be determined by the manufacturer of the system.
FR	Les valeurs données sont valables pour les produits standards. Les valeurs techniques sécuritaires pour d'autres produits spéciaux sont disponibles sur simple demande. Les données techniques sécuritaires de l'installation complète doivent être définies par l'utilisateur.

DE	EG-Konformitätserklärung
EN	CE-Declaration of Conformity
FR	Déclaration de conformité européenne

EG - Konformitätserklärung  
Declaration of Conformity  
Déclaration de conformité européenne



**Hersteller:** E. Dold & Söhne GmbH & Co. KG  
*Manufacturer: / Fabricant:*  
**Anschrift:** Bregstraße 18  
*Address: / Adresse:* 78120 Furtwangen  
Germany

**Produktbezeichnung:** Not-Aus-Modul BD5935.kk/xyzccc mit: kk = 16, 48, 52  
*Product description:* Emergency Stop Module with: xyz = 000, 200, 324, 824  
optional ccc = /60 .. /69  
*Désignation du produit:* Module d'arrêt d'urgence avec:

Das bezeichnete Produkt stimmt mit den Vorschriften folgender europäischer Richtlinien überein:  
The indicated product is in conformance with the regulations of the following european directives:  
Le produit désigné est conforme aux instructions des directives européennes:

<b>Maschinenrichtlinie:</b> <i>Machinery directive: / Directives Machines:</i>	2006/42/EG	EU-Abl. L157/24, 09.06.2006
<b>EMV - Richtlinie:</b> <i>EMC - Directive: / Directives- CEM::</i>	2014/30/EU	EU-Abl. L96/79, 29.03.2014
<b>RoHS - Richtlinie</b> <i>RoHS -Directive: / Directives - RoHS:</i>	2011/65/EU	EU-Abl. L174/88, 01.07.2011

<b>Prüfgrundsätze:</b> <i>Basis of Testing:</i>	EN ISO 13849-1:2015	EN 61508 Parts 1 - 7:2010
<i>Lignes de contrôle:</i>	EN 62061:2005 + AC:2010 + A1:2013 + A2:2015	EN 60664-1:2007
	EN 61000-6-1:2007	EN 61000-6-2:2005
	EN 61000-6-3:2007 + A1:2011	EN 61000-6-4:2007 + A1:2011

Die Übereinstimmung eines Baumusters des bezeichneten Produktes mit der oben genannten Maschinenrichtlinie wurde bescheinigt durch:

Consistency of a production sample with the marked product in accordance to the above machiney directive has been certified by:  
La conformité d'un échantillon du produit désigné aux directives machines susmentionnées a été certifiée par:

**Benannte Stelle:** TÜV Rheinland Industrie Service GmbH  
*Certification office: / l'organisme notifié:* Am Grauen Stein, 51105 Köln  
**Nummer der benannten Stelle:** 0035  
*Number of certification office: / Numéro de l'organisme notifié:*  
**Nummer der Bescheinigung:** 01/205/5045.02/21  
*Certification number: / Numéro de certificat:*  
**Ausstelldatum :** 05.11.2021  
*Date of issue: / Date de délivrance:*

**Für die Zusammenstellung der technischen Unterlagen ist bevollmächtigt:**  
*For the compilation of technical documents is authorized:*  
*Pour la composition des documents techniques est autorisé:*

Gamal Hagar, Entwicklungsleiter / R&D Manager

**Rechtsverbindliche Unterschrift:**

*Signature of authorized person:*  
*Signature autorisée :*

Christian Dold, Produktmanagement

**Ort, Datum :** Furtwangen, 11.02.2022  
*Place, Date: / Lieu, date:*

Diese Original - Erklärung bescheinigt die Übereinstimmung mit den genannten Richtlinien, beinhaltet jedoch keine Zusicherung von Eigenschaften. Die Sicherheitshinweise der Produktdokumentation sind zu beachten.

This original declaration confirms the conformity of the mentioned directives but does not comprise any guarantee of the product characteristics. The safety directives of the product documentation are to be considered.

Cette déclaration originale certifie la conformité des directives nommées mais ne comprend aucune garantie des caractéristiques du produit. Les directives de sécurité de la documentation du produit sont à considérer.

DE	UK-Konformitätserklärung
EN	UK Declaration of Conformity
FR	Déclaration de conformité UK



# UK Declaration of Conformity



**Manufacturer:** E. Dold & Söhne GmbH & Co. KG

**Address:** Bregstraße 18  
78120 Furtwangen  
Germany

**Product description:** Emergency Stop Module **BD5935.kk/xyzccc** mit: kk = 16, 48, 52  
xyz = 000, 200, 324, 824  
optional ccc = /60 .. /69

The indicated product is in conformance with the regulations of the following British regulations:

**Supply of Machinery (Safety) Regulations:** S.I. 2008 No. 1597

**Electromagnetic Compatibility Regulations:** S.I. 2016 No. 1091

**RoHS Regulations:** S.I. 2012 No. 3032

**Designated standards:** EN ISO 13849-1:2015 EN 60664-1:2007  
EN 62061:2005 + AC:2010 + A1:2013 + A2:2015 EN 61508 Parts 1-7:2010  
EN 61000-6-1:2007 EN 61000-6-2:2005  
EN 61000-6-3:2007 + A1:2011 EN 61000-6-4:2007 + A1:2011

Consistency of a production sample with the marked product in accordance to the above machiney directive has been certified by:

**Certification office:** TÜV Rheinland UK Ltd., Friars Gate(Third Floor),  
1011 Stratford Road, Shirley, Solihull B90 4BN, United Kingdom  
2571

**Number of certification office:**

**Certification number:** 01/205U/5045.00/22

**Date of issue:** 2022-11-22

**For the compilation of technical documents is authorized: Signature of authorized person:**

Dold Industries Ltd

11 Hamberts Rd. Blackall Ind. Estate  
South Woodham Ferrers  
GB - Essex, CM3 5UW

.....  
*ppa A. Dold*  
Christian Dold - Productmanagement

**Place, Date :** Furtwangen, 2022-11-24

This original declaration confirms the conformity of the mentioned directives but does not comprise any guarantee of the product characteristics. The safety directives of the product documentation are to be considered.



DE	Notizen
EN	Notice
FR	Note

