



SAFEMASTER
Emergency Stop Module
BO 5988

Translation
of the original instructions

0262923



E. Dold & Söhne GmbH & Co. KG
 Bregstraße 18 • 78120 Furtwangen • Germany
 Phone: +49 7723 654-0 • Fax +49 7723 654356
 dold-relays@dold.com • www.dold.com

Contents

Symbol and Notes Statement.....	13
General Notes	13
Designated Use	13
Safety Notes	13
Function Diagram	15
Block Diagram	15
Approvals and Markings	15
Applications	15
Indicators	15
Circuit Diagrams	16
Connection Terminals	16
Notes	16
Technical Data	16
Technical Data	17
Technical Data	17
UL-Data	17
Troubleshooting	17
Maintenance and repairs	17
Standard Types.....	18
Variants.....	18
Characteristics.....	18
Application Examples	19
Application Examples	20
Connection Technology	41
Dimensions (dimensions in mm)	41
Mounting / disassembly of the terminal strip	41
Safety related data (only instantaneous contacts).....	42
Safety related data (only delayed contacts).....	42
Safety related data	43
CE-Declaration of Conformity.....	44



Before installing, operating or maintaining this device, these instructions must be carefully read and understood.



Keep instructions for future reference



The installation must only be done by a qualified electrician!



Do not dispose of household garbage!
The device must be disposed of in compliance with nationally applicable rules and requirements.

To help you understand and find specific text passages and notes in the operating instructions, we have important information and information marked with symbols.

Symbol and Notes Statement



DANGER:
Indicates that death or severe personal injury will result if proper precautions are not taken.



WARNING:
Indicates that death or severe personal injury can result if proper precautions are not taken.



CAUTION:
Indicates that a minor personal injury can result if proper precautions are not taken.



INFO:
Referred information to help you make best use of the product.



ATTENTION:
Warns against actions that can cause damage or malfunction of the device, the device environment or the hardware / software result.

General Notes

The product hereby described was developed to perform safety functions as a part of a whole installation or machine. A complete safety system normally includes sensors, evaluation units, signals and logical modules for safe disconnections. The manufacturer of the installation or machine is responsible for ensuring proper functioning of the whole system. DOLD cannot guarantee all the specifications of an installation or machine that was not designed by DOLD. The total concept of the control system into which the device is integrated must be validated by the user. DOLD also takes over no liability for recommendations which are given or implied in the following description. The following description implies no modification of the general DOLD terms of delivery, warranty or liability claims.

Designated Use

The BO 5988 is used to interrupt a safety circuit in a safe way. It can be used to protect people and machines in applications with e-stop buttons and safety gates.

When used in accordance with its intended purpose and following these operating instructions, this device presents no known residual risks. Non-observance may lead to personal injuries and damages to property.

Safety Notes



Risk of electrocution! **Danger to life or risk of serious injuries.**

- Disconnect the system and device from the power supply and ensure they remain disconnected during electrical installation.
- The device may only be used for the applications described in the mutually applicable operating instructions / data sheet. The notes in the respective documentation must be heeded. The permissible ambient conditions must be observed.
- The contact protection of the elements connected and the insulation of the supply cables must be designed in accordance with the requirements in the operating instructions / data sheet.
- Note the VDE and local regulations, particularly those related to protective measures.



Risk of fire or other thermal hazards! **Danger to life, risk of serious injuries or property damage.**

- The device may only be used for the applications described in the mutually applicable operating instructions / data sheet. The notes in the respective documentation must be heeded. The permissible ambient conditions must be observed. In particular, the current limit curve must be heeded.
- The device may only be installed and put into operation by experts who are familiar with this technical documentation and the applicable health and safety and accident prevention regulations.



Functional error! **Danger to life, risk of serious injuries or property damage.**

- The device may only be used for the applications described in the mutually applicable operating instructions / data sheet. The notes in the respective documentation must be heeded. The permissible ambient conditions must be observed.
- The device may only be installed and put into operation by experts who are familiar with this technical documentation and the applicable health and safety and accident prevention regulations.
- The unit should be panel mounted in an enclosure rated at IP 54 or superior. Dust and dampness may lead to malfunction.



Installation fault! **Danger to life, risk of serious injuries or property damage.**

- Make sure of sufficient protection circuitry at all output contacts for capacitive and inductive loads.



Attention!

- The safety function must be triggered during commissioning.
- If a line fault occurs at the On pushbutton after the voltage is already present at S12, S22, undesired activation will take place, because this line fault does not differ from the normal closing function.
- **AUTOMATIC START !**
According to IEC/EN 60204-1 part 9.2.5.4.2 and 10.8.3 it is not allowed to restart automatically after emergency stop.
Therefore the machine control has to disable the automatic start after emergency stop.
- Opening the device or implementing unauthorized changes voids any warranty



Function Diagram

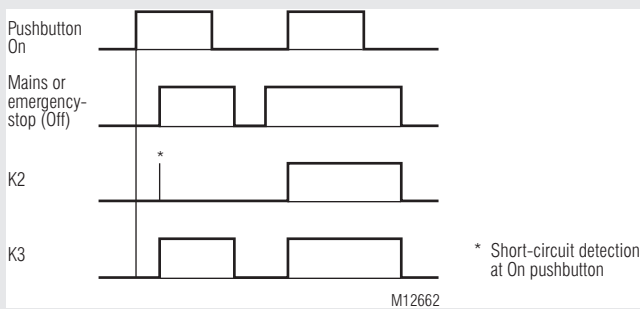

- According to
 - Performance Level (PL) e and category 4 to EN ISO 13849-1
 - SIL Claimed Level (SIL CL) 3 to IEC/EN 62061
 - Safety Integrity Level (SIL) 3 to IEC/EN 61508
- Output: max. 6 NO, 1 NC contacts or 1 NO contact for AC 250 V
- 1-channel or 2-channel connection
- Line fault detection at On pushbutton
- Feedback circuit X1-X2 for monitoring external contactors
- Integrated short-circuit and overvoltage protection
- LED displays for channels 1 and 2 and supply
- Removable terminal strips
- Wire connection: also 2 x 1.5 mm² stranded ferruled (isolated), DIN 46228-1/-2/-3-4 or 2 x 2.5 mm² stranded ferruled DIN 46228-1/-2/-3
- Optionally with release delayed NO contact to 10 min
- Optionally automatic On function after connection of operating voltage or activation via On pushbutton
- Optionally cross fault detection in emergency stop control circuit
- Optionally dual voltage version
- Width 100 mm

Approvals and Markings



*) See variants

Applications

- Protection of people and machines
- Emergency stop circuits on machines
- Monitoring of safety gates

Block Diagram

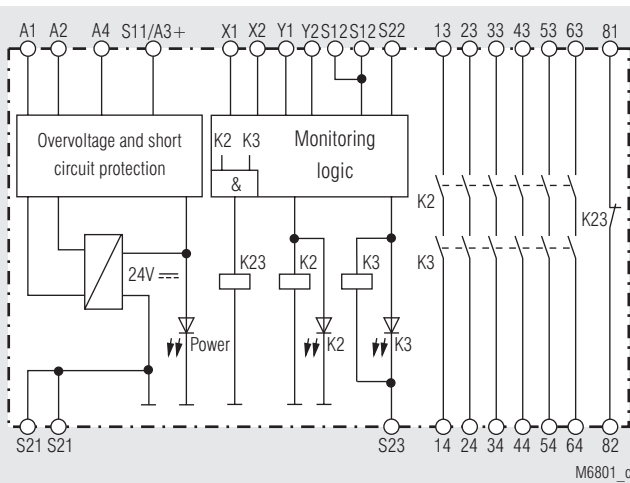

Indicators

- LED Power: On, when operating voltage present
- LED K2: On, when supply on relay K2
- LED K3: On, when supply on relay K3

Circuit Diagrams

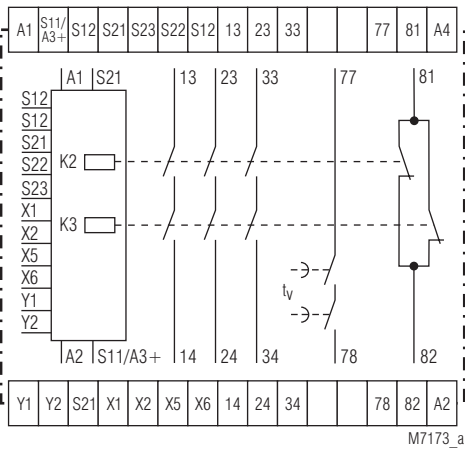

BO 5988.47

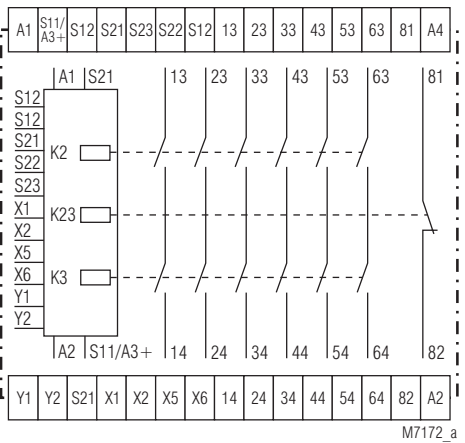

BO 5988.61

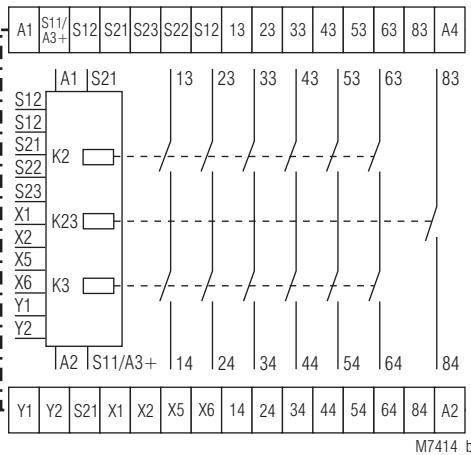

BO 5988.62

Connection Terminals

Terminal designation	Signal description
A1, S11/A3+	+ / L
A2, A4	- / N
S12, S22, S23, X2, X5, Y2	Inputs
S11, S21, X1, X6, Y1	Outputs
13, 14, 23, 24, 33, 34, 43, 44, 53, 54, 63, 64	Forcibly guided NO contacts for release circuit
81, 82	Only .47: Forcibly guided indicator output
81, 82	Only .61: indicator output (NC)
83, 84	Only .62: indicator output (NO)
77, 78	NO contact release delay Forcibly guided for release circuit

Notes

Jumper assignment for functions:

Activation via On pushbutton / or automatic On function

On push-button Y1 - Y2	Jumper X5 - X6	Function
		The output contacts are switches only after operation of the On pushbutton. Line fault monitoring at the On pushbutton
		Automatic On function for operating voltage Off/On or after emergency stop release

Line fault detection at the On pushbutton:

The output contacts cannot be closed if the On pushbutton is already closed before the voltage is applied to S12, S22 (also in the event of a line fault at the On pushbutton).

A line fault at the On pushbutton which occurs after activation of the device is recognized when switching-on takes place again and closing of the output contacts is then prevented.

If a line fault occurs at the On pushbutton after the voltage is already present at S12, S22, undesired activation will take place, because this line fault does not differ from the normal closing function.

The gold-plated contacts of the BO 5988 also mean that this module is suitable for switching small loads of 10 mVA ... 12 VA, 10 mW ... 12 W in the range 2 V ... 60 V, 2 mA ... 300 mA. The contacts also permit the maximum switching current. However, since the gold plating is burnt off at this current level, the device is no longer suitable for switching small loads after this.

One or more extension modules BN 3081 or external contactors with forcibly guided contacts may be used to multiply the number of contacts of the emergency stop module BO 5988.

Technical Data

Input

Nominal voltage U_N

BO 5988._ _ / _00:

BO 5988._ _ / _24:

DC 24 V

DC 24 V + AC 24 V

DC 24 V + AC 48 V

DC 24 V + AC 110 V

DC 24 V + AC 230 V

DC 24 V + AC 240 V

either DC 24 is connected to A3-A4 or the AC voltage to A1-A2

AC 0.8 ... 1.1 U_N

DC 0.9 ... 1.2 U_N

DC 0.8 ... 1.1 U_N

AC: approx. 6 VA, DC: approx. 3 W

50 / 60 Hz

Voltage range:

At 10 % residual ripple:

At 48 % residual ripple:

Nominal consumption:

Nominal frequency:

Control voltage

at S11:

at S21:

Control current:

Minimum voltage

at terminals S12, S22:

Recovery time:

Typ. DC + 24 V

0 V

Typ. DC 110 mA

DC 21 V with activated device

2 s

A minimum switch-off time of 10 s must be observed if the line fault monitoring function at the On pushbutton is active

Technical Data

Output

Contact

BO 5988.61:	6 NO, 1 NC indicator contact
BO 5988.62:	6 NO, 1 NO indicator contact
BO 5988.47:	3 NO, 1 NC indicator contact 1 NO release delayed

The NO contacts 13...63 / 14...64 are safety contacts.

The NC contact 81-82 and the NO contact 83-84 can only be used for monitoring.

Operate time

manual restart:	Typ. 30 ms
automatic restart:	1 s

Release time

2-channel disconnecting in secondary circuit (S12, S22 und S23):	30 ms ± 50 %
Opening in supply circuit	
BO 5988.47:	100 ms + 50 %
BO 5988.61, BO 5988.62:	50 ms + 50 %

Fault detection time at U_N

at 1-channel interruption	
At S12:	Typ. 310 ms
At S22 and S23:	30 ms ± 50 %
Time delay t_d:	Auxiliary supply is not necessary during elapse of time:

BO 5988.47/1 __:	0.1 ... 1 s	0.3 ... 3 s
	0.5 ... 5 s	1 ... 10 s
BO 5988.47/2 __:	1 s, 3 s, 5 s, 10 s	

Repeat accuracy

BO 5988.47/1 __ and BO 5988.47/2 __:	± 15 % of setting value
--------------------------------------	-------------------------

Contact type:

Nominal output voltage:	AC 250 V DC: See arc limit curve
--------------------------------	-------------------------------------

Signalling contact of

BO 5988.61 and BO 5988.62:	AC 10 ... 250 V, DC 10 ... 120 V for AC/DC 0.1 ... 1 A
----------------------------	---

Thermal current I_{th} :

See total current limit curve (max. 10 A in one contact path)

Release delayed NO contact

77-78 at BO 5988.47:	Max. 8 A
----------------------	----------

Switching capacity

to AC 15

NO contact:	3 A / AC 230 V	IEC/EN 60947-5-1
NC contact 81 / 82 (BO 5988.47):	2 A / AC 230 V	IEC/EN 60947-5-1
NC contact 81 / 82 (BO 5988.61):	1 A / AC 230 V	IEC/EN 60947-5-1

To AC 15

NO contact 13...63 / 14...64:	6 A / AC 230V at 0.25 Hz
-------------------------------	--------------------------

To DC 13

NO contact:	2 A / DC 24 V	IEC/EN 60947-5-1
NC contact 81 / 82 (BO 5988.47):	2 A / DC 24 V	IEC/EN 60947-5-1
NC contact 81 / 82 (BO 5988.61):	1 A / DC 24 V	IEC/EN 60947-5-1

To DC 13

NO contact 13...63 / 14...64:	6 A / DC 24 V at 0.1 Hz
-------------------------------	-------------------------

NO contact 77 / 78:	5 A / DC 24 V at 0.1 Hz
---------------------	-------------------------

NC contact 81 / 82 (BO 5988.47):	6 A / DC 24 V at 0.1 Hz
----------------------------------	-------------------------

Electrical life

at AC 230 V, 6 A, $\cos \varphi = 1$

instantaneous contact:	> 5 x 10 ⁵ switching cycles
------------------------	--

BO 5988.47

release delayed NO contact:	> 2 x 10 ⁵ switching cycles
-----------------------------	--

Permissible operating

frequency:	600 switching cycles / h
-------------------	--------------------------

Short circuit strength

max. fuse rating:	6 A gG / gL	IEC/EN 60947-5-1
max. line circuit breaker:	C 10 A	

Mechanical life:

	30 x 10 ⁶ switching cycles
--	---------------------------------------

Technical Data

General Data

Operating mode:

Continuous operation

Temperature range

Operation: - 15 ... + 50 °C

Storage: - 25 ... + 85 °C

Altitude: ≤ 2000 m

Clearance and creepage distances

Rated impuls voltage / pollution degree: 4 kV / 2 (basis insulation) IEC 60664-1

EMC: IEC/EN 61326-3-1

Interference suppression: Limit value class B EN 55011

Degree of protection

Housing: IP 40 IEC/EN 60529

Terminals: IP 20 IEC/EN 60529

Housing: Thermoplastic with V0 behaviour

according to UL subject 94

Vibration resistance: Amplitude 0.35 mm IEC/EN 60068-2-6
frequency 10 ... 55 Hz

Climate resistance: 15 / 050 / 04 IEC/EN 60068-1

Terminal designation: EN 50005

Wire fixing: Plus-minus terminal screws M 3.5

box terminal with wire protection

Mounting: DIN rail IEC/EN 60715

Weight: 850 g

Dimensions

Width x height x depth: 100 x 74 x 121 mm

UL-Data

Nominal voltage U_N :

BO 5988.___/_00:	DC 24 V
BO 5988.___/_24:	DC 24 V + AC 24 V DC 24 V + AC 48 V DC 24 V + AC 110 V DC 24 V + AC 230 V DC 24 V + AC 240 V either DC 24 is connected to A3-A4 or the AC voltage to A1-A2

Ambient temperature:

- 15 ... + 50 °C

Wire connection:

60 °C / 75 °C copper conductors only
AWG 18 - 16 Torque 7 lb in



Technical data that is not stated in the UL-Data, can be found in the technical data section.

Troubleshooting

Failure	Potential cause
LED "Power" does not light up	- Power supply not connected
LED "K2" lights up, but "K3" remains off	- Safety relay K2 is welded (replace device) - A 1-channel switch-off occurred on S12 (switch channel off on S22 e.g. S23)
LED "K3" lights up, but "K2" remains off	- Safety relay K3 is welded (replace device) - A 1-channel switch-off occurred on S22 e.g. S23 (switch channel off on S12)
Device cannot be activated	- The delay contacts are not yet switched off - Safety relay is welded (replace device) - Feedback circuit X1 - X2 not closed - Manual start mode: Line fault on start-button (disconnect power supply and remove fault) - Automatic start mode: S13-S14 are not bridged

Maintenance and repairs

- The device contains no parts that require maintenance.
- In case of failure, do not open the device but send it to manufacturer for repair.

Standard Types

BO 5988.61/024 DC 24 V + AC 230 V 50 / 60 Hz

Article number: 0040375

- Dual voltage version
- Output: 6 NO contacts, 1 NC contact as monitoring contact
- Width: 100 mm

BO 5988.47/124 DC 24 V + AC 230 V 50 / 60 Hz 1 ...10 s

Article number: 0040430

- Dual voltage version
- Output: 3 NO contacts, 1 NC contact as monitoring contact, 1 release delayed NO contact
- With adjustable time delay t_v to 10 s
- Width: 100 mm

Variants

BO 5988. __ / 61: With UL approval (Canada/USA)

Auxiliary supply is not necessary during elapse of time:

BO 5988.47 / 1 __: 3 NO / 1 NC contacts + t_v adjustable

BO 5988.47 / 2 __: 3 NO / 1 NC contacts + t_v fixed

Without time delay t_v :

BO 5988.61 / 0 __: 6 NO / 1 NC contacts as monitoring contact

BO 5988.62 / 0 __: 6 NO / 1 NC contacts as monitoring contact

BO 5988. __ / _00: Single voltage model

BO 5988. __ / _24: Dual voltage model

BO 5988.61 / 324: Dual voltage model 0.5 s operate delay with automatic restart

Ordering example for variants

BO 5988.47/124 1 ... 10 s DC 24 V + AC 230 V 50 / 60 Hz

Nominal frequency
Nominal voltage
Time delay
00: 1 nominal voltage
24: 2 nominal voltages
0: without t_v

Without auxiliary supply during time elapse:
1: t_v adjustable
2: t_v fixed

Contacts
Type

Characteristics

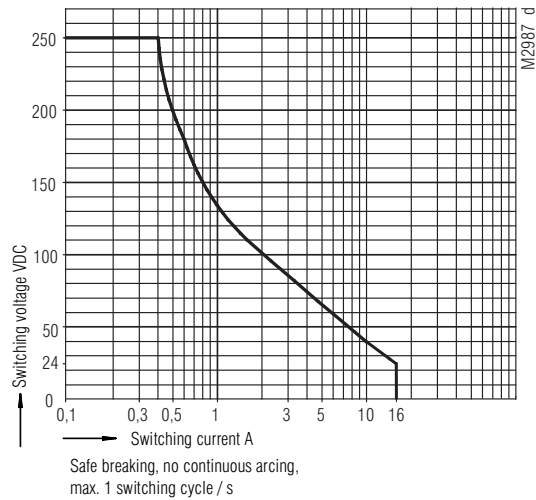

Arc limit curve with resistive load (instantaneous contact)

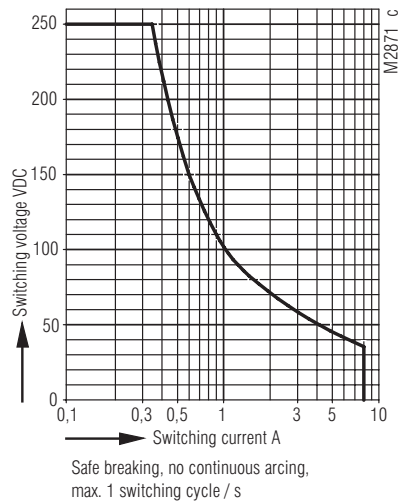

Arc limit curve with resistive load (delayed contacts)

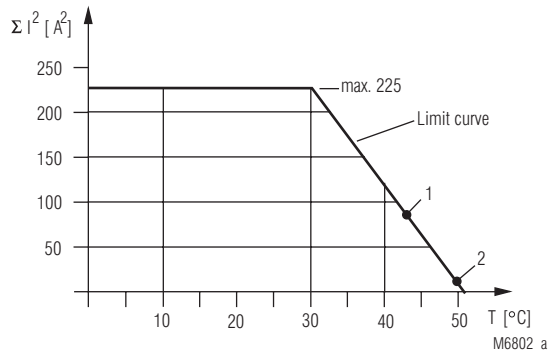

Total current limit curve

It is necessary to use the square of the currents in order to obtain a linear limit curve.

General formula for determination of the maximum ambient temperature

- Sum of currents² per safety contact = value on scale $\Sigma I^2 (A^2)$
- Max. ambient temperature T = Cross point of scale $\Sigma I^2 (A^2)$ with limit curve

Example 1

- $(4A)^2 + (4A)^2 + (4A)^2 + (4A)^2 + (4A)^2 + (4A)^2 = 96 A^2$ (Scale ΣI^2)
- Max. ambient temperature T = 43°C (point 1)

Example 2

- $(0.5 A)^2 + (1 A)^2 + (2 A)^2 + (1 A)^2 = 6.25 A^2$ (Scale ΣI^2)
- Max. ambient temperature T = 49°C (point 2)

Please note:

The total current² can still be 1.5 A² at 50°C, i.e. 0.5 A per safety contact

- $(0.5 A)^2 + (0.5 A)^2 + (0.5 A)^2 + (0.5 A)^2 + (0.5 A)^2 + (0.5 A)^2 = 1.5 A^2$
- Max. ambient temperature = 50°C

Application Examples

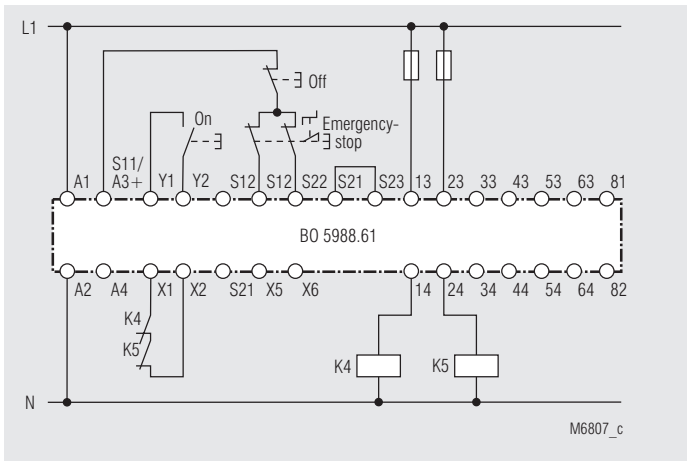

Contact reinforcement by external contactors, two-channel.

The output contacts can be reinforced by external contactors with forcibly guided contacts for switching currents > 8 A. Functioning of the external contactors is monitored by looping the NC contacts into the closing circuit (terminals X1 - X2).

Suited up to SIL3, Performance Level e, Cat. 4.

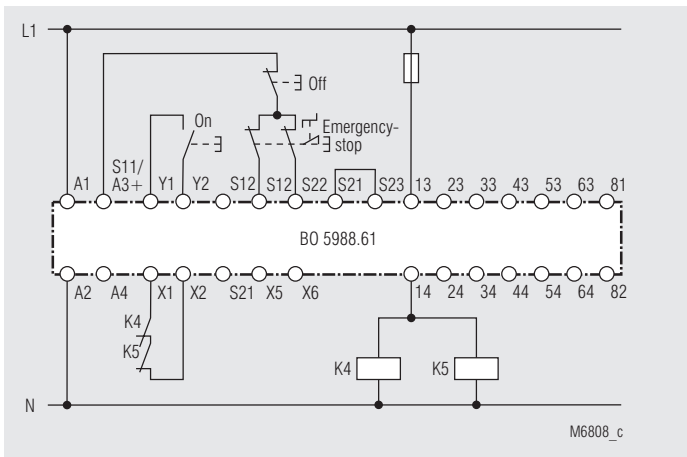

Contact reinforcement by external contactors with reduced safety level.

Suited up to SIL3, Performance Level e, Cat. 4.

DE	Anschlussstechnik
EN	Connection Technology
FR	Technologie de connexion
IT	Technologie di connessione

DE	Maßbild (Maße in mm)
EN	Dimensions (dimensions in mm)
FR	Dimensions (dimensions en mm)
IT	Dimensioni (dimensione in mm)

Klemmenleiste, abnehmbar
Terminal strip, pluggable
Bornier, amovibles
Morsettiere smontabili

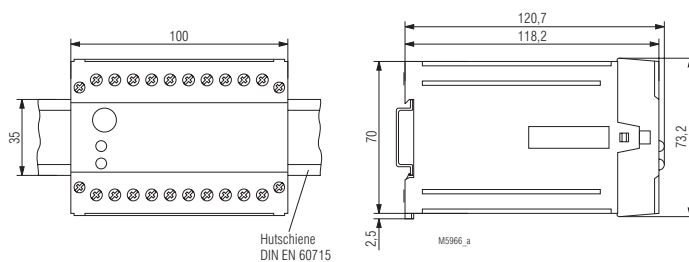
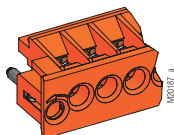

	<p>ø 4 mm / PZ 1 0,8 Nm 7 LB. IN</p>
	<p>A = 10 mm 1 x 0,5 ... 4 mm² 1 x AWG 20 to 12 2 x 0,5 ... 1,5 mm² 2 x AWG 20 to 16</p>
	<p>A = 10 mm 1 x 0,5 ... 2,5 mm² 1 x AWG 20 to 14 2 x 0,5 ... 1,5 mm² 2 x AWG 20 to 16</p>
	<p>A = 10 mm 1 x 0,5 ... 4 mm² 1 x AWG 20 to 12 2 x 0,5 ... 1,5 mm² 2 x AWG 20 to 16</p>

DE	Montage / Demontage der Klemmenleiste
EN	Mounting / disassembly of the terminal strip
FR	Montage / Démontage des borniers
IT	Montaggio / Smontaggio di morsettiere

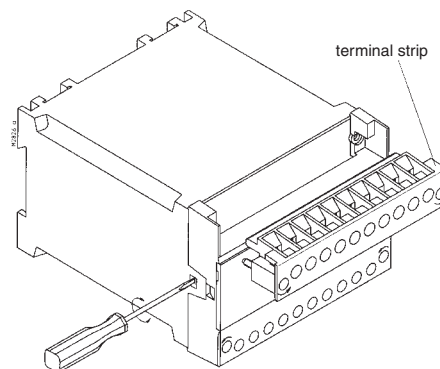

DE	Sicherheitstechnische Kenndaten (nur Sofortkontakte)
EN	Safety related data (only instantaneous contacts)
FR	Données techniques sécuritaires (contact instantané)
IT	I dati di sicurezza (solo i contatti istantanei)

DE	Sicherheitstechnische Kenndaten (nur verzögerte Kontakte)
EN	Safety related data (only delayed contacts)
FR	Données techniques sécuritaires (contact retardée)
IT	I dati di sicurezza (solo i contatti ritardati)

EN ISO 13849-1:		
Kategorie / Category:	4	
PL:	e	
MTTF _d :	290,6	a (year)
DC _{avg} :	99,0	%
d _{op} :	365	d/a (days/year)
h _{op} :	24	h/d (hours/day)
t _{cycle} :	3600	s/cycle
	± 1	/h (hour)

EN ISO 13849-1:		
Kategorie / Category:	3	
PL:	d	
MTTF _d :	671,0	a (year)
DC _{avg} :	80,2	%
d _{op} :	365	d/a (days/year)
h _{op} :	24	h/d (hours/day)
t _{cycle} :	3600	s/cycle
	± 1	/h (hour)

IEC/EN 62061 IEC/EN 61508:		
SIL CL:	3	IEC/EN 62061
SIL:	3	IEC/EN 61508
HFT ¹⁾ :	1	
DC:	99,0	%
PFH _D :	8,1E-11	h ⁻¹
T ₁ :	20	a (year)
¹⁾ HFT = Hardware-Fehlertoleranz Hardware failure tolerance Tolérance défauts Hardware Tolleranza ai guasti hardware		

IEC/EN 62061 IEC/EN 61508:		
SIL CL:	2	IEC/EN 62061
SIL:	2	IEC/EN 61508
HFT ¹⁾ :	1	
DC:	80,2	%
PFH _D :	2,2E-8	h ⁻¹
T ₁ :	20	a (year)
¹⁾ HFT = Hardware-Fehlertoleranz Hardware failure tolerance Tolérance défauts Hardware Tolleranza ai guasti hardware		



DE	Bei verzögerten Kontakten: Performance Level (PL) d und Kategorie 3 nach EN ISO 13849 für Verzögerungen bis max. 30 s. Bei längeren Verzögerungen Performance Level (PL) c und Kategorie 1. Die angeführten Kenndaten gelten für die Standardtype BO 5988.47/124 Sicherheitstechnische Kenndaten für andere Geräteausführungen erhalten Sie auf Anfrage. Die sicherheitstechnischen Kenndaten der kompletten Anlage müssen vom Anwender bestimmt werden.
EN	At delayed contacts: Performance Level (PL) d and category 3 according to EN ISO 13849 for delays up to 30 s max. For longer delays Performance Level (PL) c and category 1. The values stated above are valid for the standard type BO 5988.47/124. Safety data for other variants are available on request. The safety relevant data of the complete system has to be determined by the manufacturer of the system.
FR	Pour les contacts temporisés: Performance Level (PL) d et catégorie 3 selon EN ISO 13849 pour les temporisations jusqu'à max. 30 s. Pour toute temporisation plus longue Performance Level (PL) c et catégorie 1. Les valeurs données sont valables pour les produits standards BO 5988.47/124. Les valeurs techniques sécuritaires pour d'autres produits spéciaux sont disponibles sur simple demande. Les données techniques sécuritaires de l'installation complète doivent être définies par l'utilisateur.
IT	Con contatti ritardati: Performance Level (PL) d e categoria 3 alla EN ISO 13849, per ritardi fino a max. 30 s. Per il ritardo più lungo: Performance Level (PL) c e categoria 1. I rating sopra si applicano al tipo standard BO 5988.47/124. Dati di sicurezza per gli altri modelli sono disponibili su richiesta. I dati caratteristici relativi alla sicurezza per l'intero sistema deve essere determinato dall'utente.

DE	Sicherheitstechnische Kenndaten
EN	Safety related data
FR	Données techniques sécuritaires
IT	I dati di sicurezza

Anforderung seitens der Sicherheitsfunktion an das Gerät	Intervall für zyklische Überprüfung der Sicherheitsfunktion	
Demand to our device based on the evaluated necessary safety level of the application.	Intervall for cyclic test of the safety function	
Consigne résultant de la fonction sécuritaire de l'appareil	Interval du contrôle cyclique de la fonction sécuritaire	
Richiesta al nostro dispositivo basato sul livello di sicurezza necessary valutata dell'applicazione	Intervall per test ciclico della funzione di sicurezza	
nach; acc. to; selon; conformi a EN ISO 13849-1	PL e with Cat. 3 or Cat. 4	einmal pro Monat once per month mensuel una volta al mese
	PL d with Cat. 3	einmal pro Jahr once per year annuel una volta al mese
nach; acc. to; selon; conformi a IEC/EN 62061, IEC/EN 61508	SIL CL 3, SIL 3 with HFT = 1	einmal pro Monat once per month mensuel una volta al mese
	SIL CL 2, SIL 2 with HFT = 1	einmal pro Jahr once per year annuel una volta al mese

DE	EG-Konformitätserklärung
EN	CE-Declaration of Conformity
FR	Déclaration de conformité européenne
IT	Dichiarazione di conformità CE

EG - Konformitätserklärung
Declaration of Conformity
Déclaration de conformité européenne



Hersteller: E. Dold & Söhne GmbH & Co. KG

Manufacturer: / Fabricant:

Anschrift:

Address: / Adresse:

Bregstraße 18
78120 Furtwangen
Germany

Produktbezeichnung: Not-Aus-Modul **BO5988.kkccc** mit: kk = 47, 61, 62
Product description: Emergency Stop Module **BO5988.kk/yzccccc** with: y = 0, 1, 2, 3
Désignation du produit: Module d'arrêt d'urgence avec: zz = 00,05,24
optional ccc = /60 ... /69

Das bezeichnete Produkt stimmt mit den Vorschriften folgender europäischer Richtlinien überein:

The indicated product is in conformance with the regulations of the following european directives:

Le produit désigné est conforme aux instructions des directives européennes:

Maschinenrichtlinie: 2006/42/EG EU-Abl. L157/24, 09.06.2006
Machinery directive: / Directives Machines:
EMV - Richtlinie: 2014/30/EU EU-Abl. L96/79, 29.03.2014
EMC - Directive: / Directives- CEM::
RoHS - Richtlinie 2011/65/EU EU-Abl. L174/88, 01.07.2011
RoHS -Directive: / Directives - RoHS:

Prüfgrundsätze: EN ISO 13849-1:2015 EN 61508 Parts 1-7:2010
Basis of Testing: EN IEC 62061:2021 EN 60664-1:2007
Lignes de contrôle: EN IEC 60664-1:2020 + AC:2020 EN 61000-6-2:2005 + AC:2005
EN 61000-6-3:2007 + A1:2011 + AC:2012 EN 61000-6-4:2007 + A1:2011
EN 61000-6-7:2015 EN 61326-1:2013
EN 61326-3-1:2017

Die Übereinstimmung eines Baumusters des bezeichneten Produktes mit der oben genannten Maschinenrichtlinie wurde bescheinigt durch:

Consistency of a production sample with the marked product in accordance to the above machiney directive has been certified by:

La conformité d'un échantillon du produit désigné aux directives machines susmentionnées a été certifiée par:

Benannte Stelle: TÜV Rheinland Industrie Service GmbH

Certification office: / l'organisme notifié:

Nummer der benannten Stelle: NB0035

Number of certification office: / Numéro de l'organisme notifié:

Nummer der Bescheinigung: 01/205/5040.02/22

Certification number: / Numéro de certificat:

Ausstelldatum : 24.06.2022

Date of issue: / Date de délivrance:

Für die Zusammenstellung der technischen Unterlagen ist bevollmächtigt:

For the compilation of technical documents is authorized:

Pour la composition des documents techniques est autorisé:

.....
Gamal Hagar, Entwicklungsleiter / R&D Manager

Rechtsverbindliche Unterschrift:

Signature of authorized person:

Signature autorisée :

.....
Christian Dold, Produktmanagement / Productmanagement

Ort, Datum : Furtwangen, 29.06.2022

Place, Date: / Lieu, date:

Diese Original - Erklärung bescheinigt die Übereinstimmung mit den genannten Richtlinien, beinhaltet jedoch keine Zusicherung von Eigenschaften. Die Sicherheitshinweise der Produktdokumentation sind zu beachten.

This original declaration confirms the conformity of the mentioned directives but does not comprise any guarantee of the product characteristics. The safety directives of the product documentation are to be considered.

Cette déclaration originale certifie la conformité des directives nommées mais ne comprend aucune garantie des caractéristiques du produit. Les directives de sécurité de la documentation du produit sont à considérer.