



**SAFEMASTER**  
**Emergency Stop Module**  
**with voltage failure detection**  
**BH 5903, BL 5903**

**Translation**  
**of the original instructions**

**0262980**



**E. Dold & Söhne GmbH & Co. KG**  
 Bregstraße 18 • 78120 Furtwangen • Germany  
 Phone: +49 7723 654-0 • Fax +49 7723 654356  
 dold-relays@dold.com • www.dold.com

# Contents

Symbol and Notes Statement.....	11
General Notes .....	11
Designated Use .....	11
Safety Notes .....	11
Function Diagram .....	13
Indicators .....	13
Circuit Diagrams .....	13
Approvals and Markings .....	13
Applications .....	13
Circuit Diagrams .....	14
Connection Terminals .....	14
Technical Data .....	14
Technical Data .....	15
UL-Data .....	15
Standard Type.....	15
Variants.....	15
Characteristic.....	15
Fault Indication By Flashing Code.....	16
Application Examples .....	16
Connection Technology .....	25
Dimensions (dimensions in mm) .....	25
Mounting / disassembly of the terminal blocks .....	25
Safety Related Data BH/BL 5903.__/00000 .....	26
Safety Related Data BH/BL 5903.__/00020 .....	26
CE-Declaration of Conformity .....	27
UKCA-Declaration of Conformity.....	28



Before installing, operating or maintaining this device, these instructions must be carefully read and understood.



Keep instructions for future reference



The installation must only be done by a qualified electrician!



Do not dispose of household garbage!  
The device must be disposed of in compliance with nationally applicable rules and requirements.

To help you understand and find specific text passages and notes in the operating instructions, we have important information and information marked with symbols.

### Symbol and Notes Statement



**DANGER:**  
Indicates that death or severe personal injury will result if proper precautions are not taken.



**WARNING:**  
Indicates that death or severe personal injury can result if proper precautions are not taken.



**CAUTION:**  
Indicates that a minor personal injury can result if proper precautions are not taken.



**INFO:**  
Referred information to help you make best use of the product.



**ATTENTION:**  
Warns against actions that can cause damage or malfunction of the device, the device environment or the hardware / software result.

### General Notes

The product hereby described was developed to perform safety functions as a part of a whole installation or machine. A complete safety system normally includes sensors, evaluation units, signals and logical modules for safe disconnections. The manufacturer of the installation or machine is responsible for ensuring proper functioning of the whole system. DOLD cannot guarantee all the specifications of an installation or machine that was not designed by DOLD. The total concept of the control system into which the device is integrated must be validated by the user. DOLD also takes over no liability for recommendations which are given or implied in the following description. The following description implies no modification of the general DOLD terms of delivery, warranty or liability claims.

### Designated Use

The BH 5903 e.g. BL 5903 is used to interrupt a safety circuit in a safe way. It can be used to protect people and machines in applications with e-stop buttons in plants that need to reset automatically after a power failure, e.g. in compressor controls, water and sewage water treatment plants. When used in accordance with its intended purpose and following these operating instructions, this device presents no known residual risks. Non-observance may lead to personal injuries and damages to property.

### Safety Notes



#### **Risk of electrocution!** **Danger to life or risk of serious injuries.**

- Disconnect the system and device from the power supply and ensure they remain disconnected during electrical installation.
- The device may only be used for the applications described in the mutually applicable operating instructions / data sheet. The notes in the respective documentation must be heeded. The permissible ambient conditions must be observed.
- The contact protection of the elements connected and the insulation of the supply cables must be designed in accordance with the requirements in the operating instructions / data sheet.
- Note the VDE and local regulations, particularly those related to protective measures.



#### **Risk of fire or other thermal hazards!** **Danger to life, risk of serious injuries or property damage.**

- The device may only be used for the applications described in the mutually applicable operating instructions / data sheet. The notes in the respective documentation must be heeded. The permissible ambient conditions must be observed. In particular, the current limit curve must be heeded.
- The device may only be installed and put into operation by experts who are familiar with this technical documentation and the applicable health and safety and accident prevention regulations.



#### **Functional error!** **Danger to life, risk of serious injuries or property damage.**

- The device may only be used for the applications described in the mutually applicable operating instructions / data sheet. The notes in the respective documentation must be heeded. The permissible ambient conditions must be observed.
- The device may only be installed and put into operation by experts who are familiar with this technical documentation and the applicable health and safety and accident prevention regulations.
- The unit should be panel mounted in an enclosure rated at IP 54 or superior. Dust and dampness may lead to malfunction.



#### **Installation fault!** **Danger to life, risk of serious injuries or property damage.**

- Make sure of sufficient protection circuitry at all output contacts for capacitive and inductive loads.



#### **Attention!**

- The safety function must be triggered during commissioning.
- The BH 5903 e.g. BL 5903 stores the state of emergency stop. After pressing and releasing the e-stop button the unit can only be reset by pressing the button. If the unit switches off because of phase failure it resets automatically when the voltage returns.
- The NC contact 31-32 (BH 5903.22 e.g. BL 5903.22) is only a monitoring contact.
- The unit monitors how long the on button is pressed. Is the duration longer then 3 sec it does not switch on.
- Opening the device or implementing unauthorized changes voids any warranty



## SAFEMASTER Emergency Stop Module With Voltage Failure Detection BH 5903, BL 5903



0235200

- According to
  - Performance Level (PL) e and category 4 to EN ISO 13849-1
  - SIL Claimed Level (SIL CL) 3 to IEC/EN 62061
  - Safety Integrity Level (SIL 3) to IEC/EN 61508
- E-stop with latching function
- Automatic start when voltage returns after phase failure when no E-Stop was operated before phase failure.
- Reset after E-stop with push button
- Output max. 3 NO contacts, see contacts
- B\_5903.\_\_/00000: 1 E-stop loop 2-channel operated
- B\_5903.\_\_/00020: 2 E-stop loops single channel operated
- Cross fault monitoring
- Feedback loop for external contact reinforcement
- Short circuit and broken wire detection on all inputs
- LED indication for channel 1 and 2 and for diagnostics
- Removable terminal strips
- Wire connection: also 2 x 1.5 mm<sup>2</sup> stranded ferruled (isolated), DIN 46228-1/-2/-3/-4 or
- 2 x 2.5 mm<sup>2</sup> stranded ferruled DIN 46228-1/-2/-3
- BH 5903: width 45 mm
- BL 5903: width 90 mm

### Function Diagram

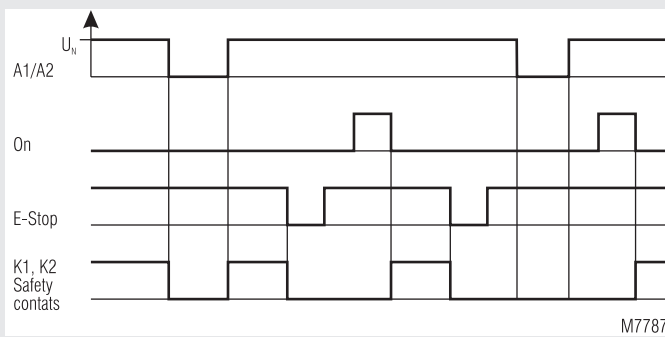

M7787

### Approvals and Markings



\* See variants

### Indicators

- Upper yellow LEDs  
run 1, run 2: On when unit works correct, fault signal via flashing code
- Lower green LEDs  
K1, K2: On when K1, K2 energized

### Applications

- For plants, that should start automatically at return of voltage after phase failure. E.g. Compressor plants, water and sewage water plants.

### Circuit Diagrams

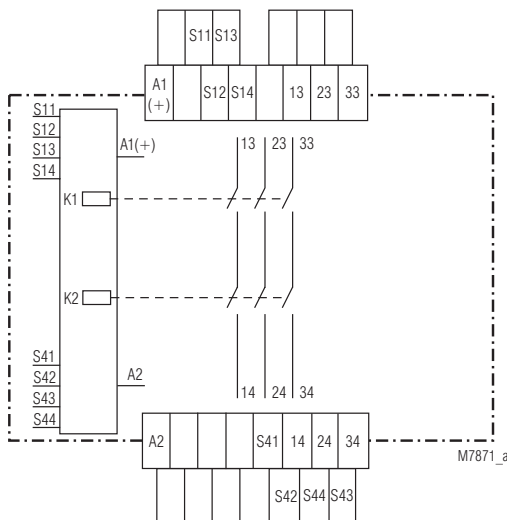

BH 5903.03

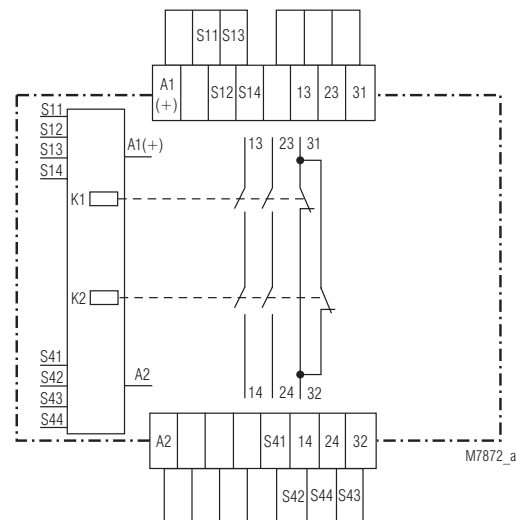

BH 5903.22

## Circuit Diagrams

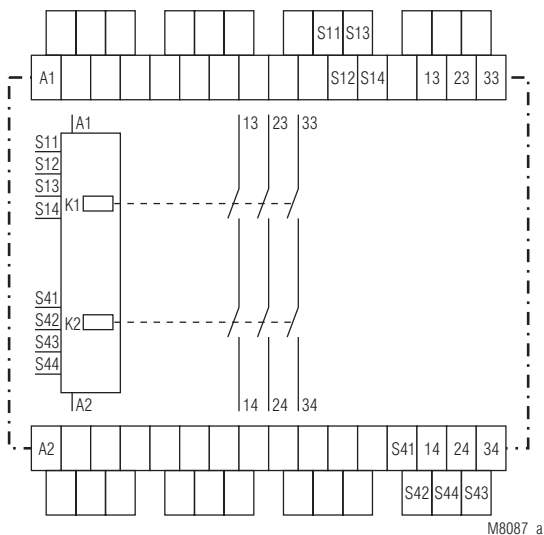

M8087\_a

BL 5903.03

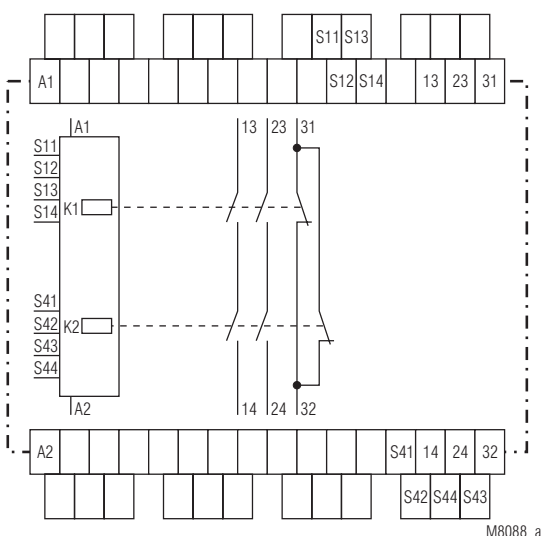

M8088\_a

BL 5903.22

## Connection Terminals

Terminal designation	Signal description
A1+	+ / L
A2	- / N
S12, S14, S42, S44	Inputs
S11, S13, S41, S43	Outputs
13, 14, 23, 24, 33, 34	Forcibly guided NO contacts for release circuit
31,32	Forcibly guided NO contacts for indicator signal

## Technical Data

### Input

<b>Nominal voltage <math>U_N</math>:</b>	BH 5903 DC 24 V	BL 5903 AC 24, 110, 230 V
<b>Voltage range:</b>	-	0.8 ... 1.1 $U_N$
at max. 5 % residual ripple:	0.85 ... 1.15 $U_N$	-
<b>Nominal consumption:</b>	Max. 170 mA	Max. 7 VA
<b>Nennfrequenz:</b>	-	50 / 60 Hz
<b>Control voltage over S11, S13, S41, S43:</b>	Pulses max. 23 V at $U_N$	
<b>Control current over S12, S14, S42, S44:</b>	Each 4.5 mA at $U_N$	
<b>Min. voltage at terminals S12, S14, S42, S44:</b>	DC 16 V	
<b>Short circuit protection:</b>	Internal with PTC	

### Output

#### Contact

BH 5903.03:	3 NO contacts
BH 5903.22:	2 NO, 1 NC contacts (only to be used as monitoring contact)

#### Operate delay typ. at $U_N$ :

Manual start:	Max. 45 ms
Automatic start:	Max. 800 ms, if voltage failure > approx. 150 ms Max. 7 s, if voltage failure < approx. 150 ms

#### Release delay typ. at $U_N$ :

Disconnecting the supply:	Max. 18 ms
Disconnecting S12, S22:	15 ms
<b>Contact type:</b>	Relay, forcibly guided
<b>Output rated voltage:</b>	AC 250 V DC: see continuous limit curve
<b>Switching of low loads:</b>	$\geq 100$ mV
<b>Thermal current <math>I_{th}</math>:</b>	5 A

#### Switching capacity

to AC 15:		
NO contact:	3 A / AC 230 V	IEC/EN 60947-5-1
NC contact:	2 A / AC 230 V	IEC/EN 60947-5-1
to DC 13 at 0.1 Hz:	8 A / DC 24 V	IEC/EN 60947-5-1

#### Electrical life

to AC 15 at 2 A, AC 230 V:	10 <sup>5</sup> switching cycles	IEC/EN 60947-5-1
----------------------------	----------------------------------	------------------

#### Permissible switching frequency:

max. 1200 switching cycles / h

#### Short circuit strength

max. fuse rating:	6 A gG / gL	IEC/EN 60947-5-1
line circuit breaker:	C 8 A	

#### Mechanical life:

10 x 10<sup>6</sup> switching cycles

### General Data

#### Operating mode:

Continuous operation

#### Temperature range

Operation:	$\pm 0$ ... + 50 °C
Storage:	- 25 ... + 85 °C
<b>Altitude:</b>	$\leq 2000$ m

#### Clearance and creepage distances

Rated impulse voltage / pollution degree:	4 kV / 2 (basis insulation)	IEC/EN 60664-1
---	-----------------------------	----------------

#### EMC

Electrostatic discharge:	8 kV (air)	IEC/EN 61000-4-2
HF-irradiation		
80 MHz ... 2.7 GHz:	10 V / m	IEC/EN 61000-4-3
Fast transients:	2 kV	IEC/EN 61000-4-4
Surge voltages between		
wires for power supply:	1 kV	IEC/EN 61000-4-5
between wire and ground:	2 kV	IEC/EN 61000-4-5
HF-wire guided:	10 V	IEC/EN 61000-4-6
Interference suppression:	Limit value class A*)	EN 55011

\*) The device is designed for the usage under industrial conditions (Class A, EN 55011). When connected to a low voltage public system (Class B, EN 55011) radio interference can be generated. To avoid this, appropriate measures have to be taken.

## Technical Data

### Degree of protection

Housing: IP 40 IEC/EN 60529  
 Terminals: IP 20 IEC/EN 60529

**Housing:** Thermoplastic with V0 behaviour according to UL subject 94

**Vibration resistance:** Amplitude 0.35 mm IEC/EN 60068-2-6 frequency 10 ... 55 Hz

### Shock resistance:

Acceleration: 10 g  
 Duration of impulses: 16 ms

Number of shocks: 1000 per axis on all three axes

**Climate resistance:** 0 / 050 / 04 IEC/EN 60068-1

**Terminal designation:** EN 50005

**Wire fixing:** Box terminal with wire protection, removable terminal strips

**Fixing torque:** 0.8 Nm

**Mounting:** DIN rail IEC/EN 60715

**Weight:** 320 g

## Dimensions

### Width x height x depth

BH 5903: 45 x 84 x 121 mm

BL 5903: 90 x 84 x 121 mm

## UL-Data

The safety functions were not evaluated by UL. Listing is accomplished according to requirements of Standard UL 508, "general use applications"

**Nominal voltage  $U_N$ :** DC 24 V

**Ambient temperature:** 0 ... + 50 °C

### Switching capacity:

Ambient temperature 50°C: Pilot duty B300  
 5A 250Vac G.P.  
 5A 24Vdc

Semiconductor outputs: 24Vdc, 100 mA

### Wire connection:

60°C / 75°C copper conductors only  
 AWG 20 - 12 Sol Torque 0.8 Nm  
 AWG 20 - 14 Str Torque 0.8 Nm



Technical data that is not stated in the UL-Data, can be found in the technical data section.

## Standard Type

BL 5903.03/00000 AC 230 V

Article number:

0053510

- Output: 3 NO contacts
- for 1 E-stop loop, 2 channel operated
- Nominal voltage  $U_N$ : AC 230 V
- Width: 45 mm

## Variants

B\_ 5903.\_./00000: For 1 E-stop loop 2- channel operated

B\_ 5903.\_./00020: For 2 E-Stop loops singel channel operated

BH 5903.\_./\_/\_/\_/\_/61: With UL-approval

## Ordering example for variant

B\_ 5903. \_ / \_ / \_ / \_ / 61 V

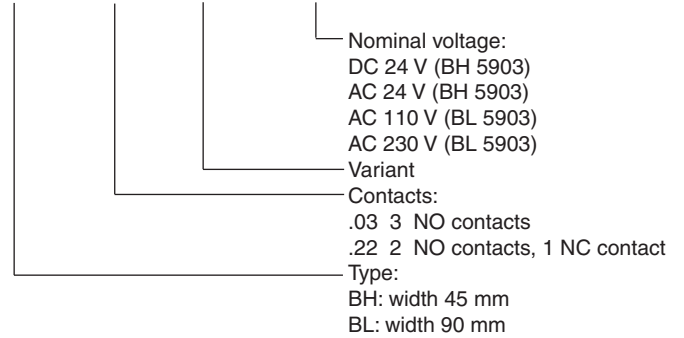

## Characteristic

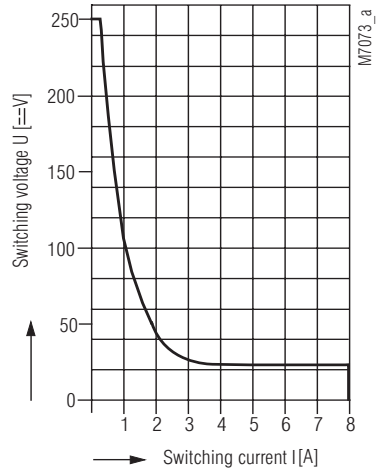

Safe breaking, no continuous arcing under the curve, max. 1 switching cycle/s

Continuous limit curve

## Fault Indication By Flashing Code

The failure codes are displayed by a flashing sequence of the upper yellow LEDs run 1, run 2. Flashing frequency: env. 0.5 s on, 0.05 s off, end of the sequence: env. 2 s off. It is possible that the two processors show different failure codes. If a failure is displayed, the relays K1 and K2 are switched off.

The module BH 5904 shows 2 types of failure codes:

### 1. FAILURE type 1:

These failures are serious and do not allow further operation of the module. The module can only be reset by switching the power supply off and on again.

### 2. FAILURE type 2:

This failure is concerning the function faults in conjunction with the safety controller. The module can be reset by pressing the reset button.

### Failure type 1

N <sup>o</sup> *)	Description	Mesures et conseils
0	Internal module failure (LEDs are continuously off)	If both LEDs stay off, the module is defective and has to be repaired.
6	Undervoltage detection or Overvoltage detection	1) Left LED is flashing: The supply voltage dropped below the permitted value (< approx. 0.85 U <sub>N</sub> ) 2) Right LED is flashing: The supply voltage went over the permitted value (> approx. 1.15 U <sub>N</sub> + 5 % residual ripple)
7	Input failure	A short circuit has been detected on the inputs of the unit or the 2 signals of a 2-channel sensor (feedback circuit, start signal of controller, valve) do not correspond (short circuit, broken wire or other fault)
8	Failure on relay output	Output relay defective 1) Check circuit and current. 2) The relay service life is crossing
9	Internal module failure	Please try to evaluate the circumstances that lead to this fault and check with the supplier or manufacturer.
10		
11	Internal module failure	The module has to be repaired
12		
13		
14		

\*) No.: Number of flash pulses in a series

### Failure type 2

N <sup>o</sup> *)	Description	Mesures et conseils
1	E-stop activated	
2	Fault on reset button	1) The start button must not be pressed longer than 3 sec. 2) During start up of the unit and initialising the start button must not be pressed
4	Switch off fault	The unit showed already a fault before switching off
6	Feedback failure	Both LED are flashing Feedback on S41/S42 not closed

\*) No.: Number of flash pulses in a series

## Application Examples

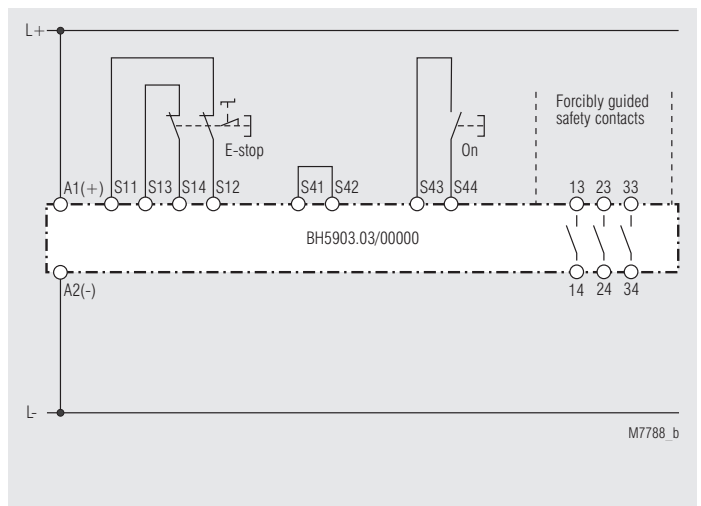

BH 5903.03/00000 with one E-Stop loop (2-channel), automatic restart after phase failure and manual restart after E-stop. Automatic reset is only active when no E-Stop was operated before phase failure.

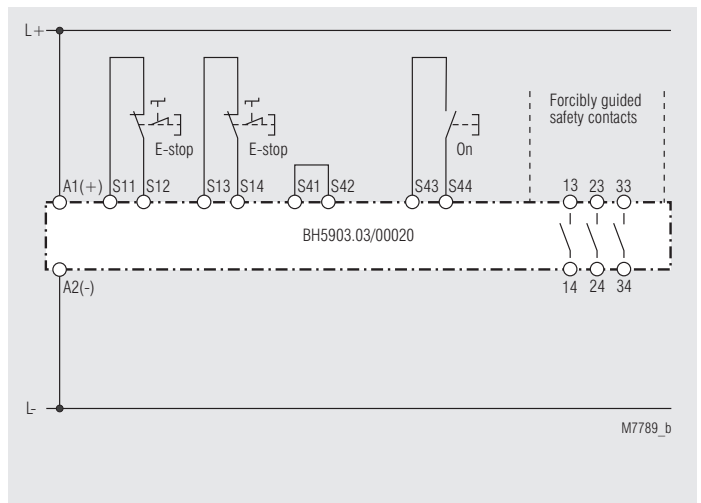

BH 5903.03/00020 with two E-Stop loops (single-channel), automatic restart after phase failure and manual restart after E-stop. Automatic reset is only active when no E-Stop was operated before phase failure. Max. Cat. 3, PL d because of fault exclusion in the wiring.

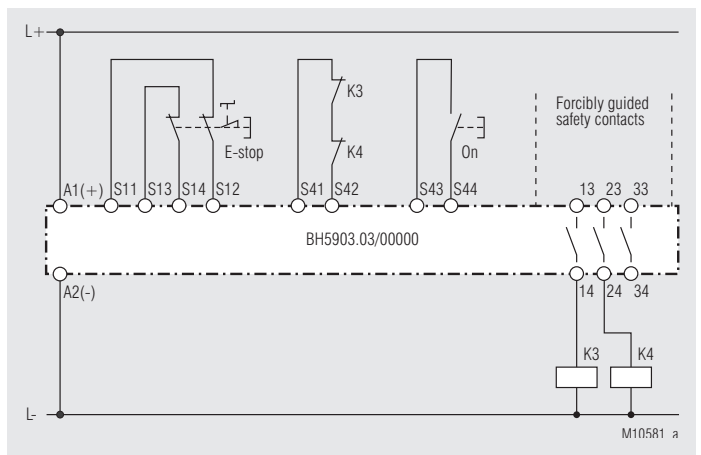

BH 5903 with external contact reinforcement

DE	<b>Anschlussstechnik</b>
EN	<b>Connection Technology</b>
FR	<b>Technologie de connexion</b>

Schraubklemmen, abnehmbar  
Screw terminals, pluggable  
Bornes à vis, amovibles

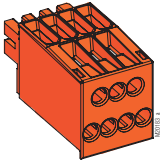

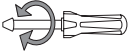
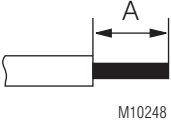
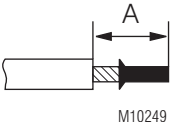
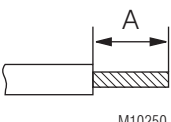
	<p>∅ 4 mm / PZ 1 0,8 Nm 7 LB. IN</p>
	<p>A = 10 mm 1 x 0,5 ... 4 mm<sup>2</sup> 1 x AWG 20 to 12 2 x 0,5 ... 1,5 mm<sup>2</sup> 2 x AWG 20 to 16</p>
	<p>A = 10 mm 1 x 0,5 ... 2,5 mm<sup>2</sup> 1 x AWG 20 to 14 2 x 0,5 ... 1,5 mm<sup>2</sup> 2 x AWG 20 to 16</p>
	<p>A = 10 mm 1 x 0,5 ... 4 mm<sup>2</sup> 1 x AWG 20 to 12 2 x 0,5 ... 1,5 mm<sup>2</sup> 2 x AWG 20 to 16</p>

DE	<b>Maßbild (Maße in mm)</b>
EN	<b>Dimensions (dimensions in mm)</b>
FR	<b>Dimensions (dimensions en mm)</b>

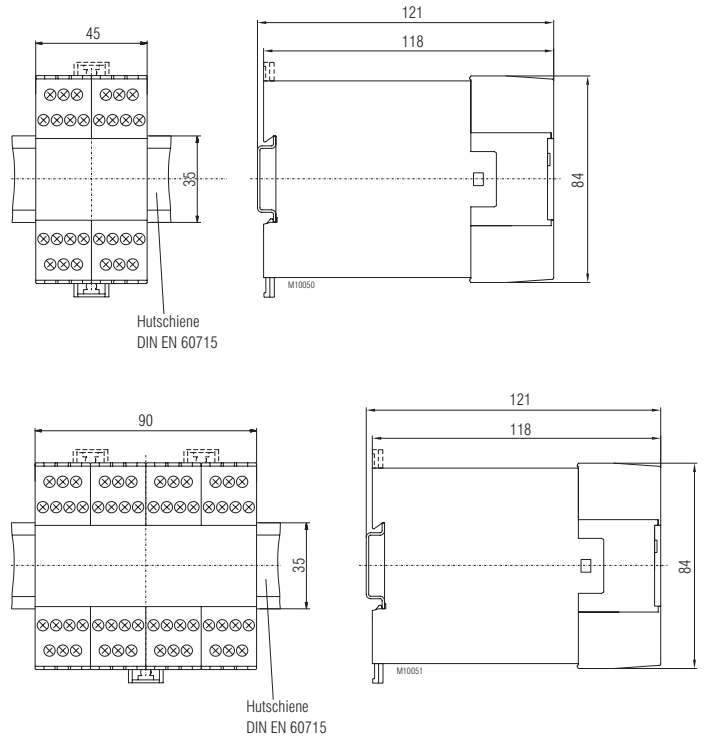

DE	<b>Montage / Demontage der Klemmenblöcke</b>
EN	<b>Mounting / disassembly of the terminal blocks</b>
FR	<b>Montage / Démontage des borniers amovibles</b>

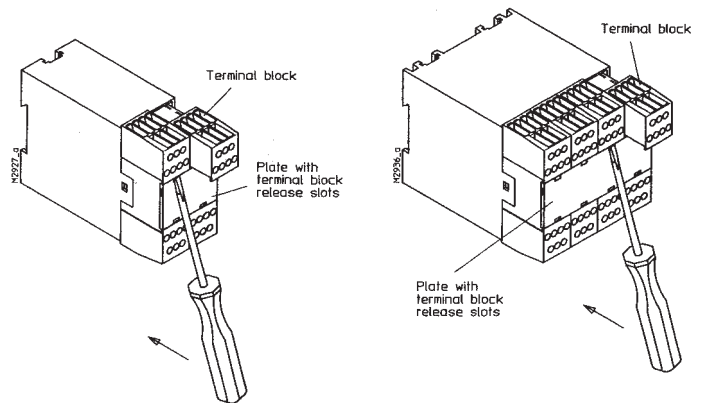

DE	Sicherheitstechnische Kenndaten BH/BL 5903._./00000
EN	Safety Related Data BH/BL 5903._./00000
FR	Données techniques sécuritaires BH/BL 5903._./00000

DE	Sicherheitstechnische Kenndaten BH/BL 5903._./00020
EN	Safety Related Data BH/BL 5903._./00020
FR	Données techniques sécuritaires BH/BL 5903._./00020

<b>EN ISO 13849-1:</b>		
Kategorie / Category:	4	
PL:	e	
MTTF <sub>d</sub> :	181	a (year)
DC <sub>avg</sub> :	99	%
d <sub>op</sub> :	365	d/a (days/year)
h <sub>op</sub> :	24	h/d (hours/day)
t <sub>cycle</sub> :	3600	s/cycle
	≅ 1	/h (hour)

<b>EN ISO 13849-1:</b>		
Kategorie / Category:	3	
PL:	d	
MTTF <sub>d</sub> :	186	a (year)
DC <sub>avg</sub> :	99	%
d <sub>op</sub> :	365	d/a (days/year)
h <sub>op</sub> :	24	h/d (hours/day)
t <sub>cycle</sub> :	3600	s/cycle
	≅ 1	/h (hour)

<b>IEC/EN 62061 IEC/EN 61508:</b>		
SIL CL:	3	IEC/EN 62061
SIL	3	IEC/EN 61508
HFT <sup>1)</sup> :	1	
DC <sub>avg</sub> :	99	%
PFH <sub>D</sub> :	5,6E-10	h <sup>-1</sup>
<sup>1)</sup> HFT = Hardware-Fehlertoleranz Hardware failure tolerance Tolérance défauts Hardware		

<b>IEC/EN 62061 IEC/EN 61508:</b>		
SIL CL:	2	IEC/EN 62061
SIL	2	IEC/EN 61508
HFT <sup>1)</sup> :	1	
DC <sub>avg</sub> :	99	%
PFH <sub>D</sub> :	1,6E-08	h <sup>-1</sup>
<sup>1)</sup> HFT = Hardware-Fehlertoleranz Hardware failure tolerance Tolérance défauts Hardware		



DE	Die angeführten Kenndaten gelten für die Standardtype. Sicherheitstechnische Kenndaten für andere Geräteausführungen erhalten Sie auf Anfrage. Die sicherheitstechnischen Kenndaten der kompletten Anlage müssen vom Anwender bestimmt werden.
EN	The values stated above are valid for the standard type. Safety data for other variants are available on request. The safety relevant data of the complete system has to be determined by the manufacturer of the system.
FR	Les valeurs données sont valables pour les produits standards. Les valeurs techniques sécuritaires pour d'autres produits spéciaux sont disponibles sur simple demande. Les données techniques sécuritaires de l'installation complète doivent être définies par l'utilisateur.

Anforderung seitens der Sicherheitsfunktion an das Gerät Demand to our device based on the evaluated necessary safety level of the application. Consigne résultant de la fonction sécuritaire de l'appareil	Intervall für zyklische Überprüfung der Sicherheitsfunktion Intervall for cyclic test of the safety function Interval du contrôle cyclique de la fonction sécuritaire	
Nach, acc. to, selon EN ISO 13849-1	PL e with Cat. 3 or Cat. 4	Einmal pro Monat Once per month Mensuel
	PL d with Cat. 3	Einmal pro Jahr Once per year Annuel
Nach, acc. to, selon IEC/EN 62061, IEC/EN 61508	SIL CL 3, SIL 3 with HFT = 1	Einmal pro Monat Once per month Mensuel
	SIL CL 2, SIL 2 with HFT = 1	Einmal pro Jahr Once per year Annuel

DE	EG-Konformitätserklärung
EN	CE-Declaration of Conformity
FR	Déclaration de conformité européenne

EG - Konformitätserklärung  
Declaration of Conformity  
Déclaration de conformité européenne



**Hersteller:** E. Dold & Söhne GmbH & Co. KG  
*Manufacturer: / Fabricant:*  
**Anschrift:** Bregstraße 18  
*Address: / Adresse:* 78120 Furtwangen  
Germany

**Produktbezeichnung:** Not-Aus-Modul mit Netzausfallerkennung **BH5903.kk/00MF2/ccc** mit: kk = 03, 22  
*Product description:* Emergency Stop Module with voltage failure detection **BH5903.kk/00vvv/ccc** **with:** vvv = 000, 020  
*Désignation du produit:* Module d'arrêt d'urgence avec détection des coupures de réseau **avec:** optional ccc = /60 ... / 69

Das bezeichnete Produkt stimmt mit den Vorschriften folgender europäischer Richtlinien überein:  
The indicated product is in conformance with the regulations of the following european directives:  
Le produit désigné est conforme aux instructions des directives européennes:

<b>Maschinenrichtlinie:</b> <i>Machinery directive: / Directives Machines:</i>	2006/42/EG	EU-Abl. L157/24, 09.06.2006
<b>EMV - Richtlinie:</b> <i>EMC - Directive: / Directives- CEM::</i>	2014/30/EU	EU-Abl. L96/79, 29.03.2014
<b>RoHS - Richtlinie</b> <i>RoHS -Directive: / Directives - RoHS:</i>	2011/65/EU	EU-Abl. L174/88, 01.07.2011

<b>Prüfgrundsätze:</b> <i>Basis of Testing:</i>	EN ISO 13849-1:2015	EN 61508 Parts 1,2 :2010
<i>Lignes de contrôle:</i>	EN 62061:2005 + AC:2010 + A1:2013 + A2:2015	EN 60664-1:2007
	EN 61000-6-2:2005	EN 61000-6-4:2007 + A1:2011
	EN 55011:2016 + A1:2017	

Die Übereinstimmung eines Baumusters des bezeichneten Produktes mit der oben genannten Maschinenrichtlinie wurde bescheinigt durch:

Consistency of a production sample with the marked product in accordance to the above machiney directive has been certified by:  
La conformité d'un échantillon du produit désigné aux directives machines susmentionnées a été certifiée par:

**Benannte Stelle:** TÜV Rheinland Industrie Service GmbH  
*Certification office: / l'organisme notifié:* Am Grauen Stein, 51105 Köln  
**Nummer der benannten Stelle:** 0035  
*Number of certification office: / Numéro de l'organisme notifié:*  
**Nummer der Bescheinigung:** 01/205/0760.03/22  
*Certification number: / Numéro de certificat:*  
**Ausstellungsdatum :** 22.02.2022  
*Date of issue: / Date de délivrance:*

**Für die Zusammenstellung der technischen Unterlagen ist bevollmächtigt:**  
*For the compilation of technical documents is authorized:*  
*Pour la composition des documents techniques est autorisé:*

Gamal Hagar, Entwicklungsleiter / R&D Manager

**Rechtsverbindliche Unterschrift:**

*Signature of authorized person:*  
*Signature autorisée :*

Christian Dold, Produktmanagement / Productmanagement

**Ort, Datum :** Furtwangen, 24.08.2022  
*Place, Date: / Lieu, date:*

Diese Original - Erklärung bescheinigt die Übereinstimmung mit den genannten Richtlinien, beinhaltet jedoch keine Zusicherung von Eigenschaften. Die Sicherheitshinweise der Produktdokumentation sind zu beachten.

This original declaration confirms the conformity of the mentioned directives but does not comprise any guarantee of the product characteristics. The safety directives of the product documentation are to be considered.

Cette déclaration originale certifie la conformité des directives nommées mais ne comprend aucune garantie des caractéristiques du produit. Les directives de sécurité de la documentation du produit sont à considérer.

DE	UKCA-Konformitätserklärung
EN	UKCA-Declaration of Conformity
FR	Déclaration de conformité UKCA

## UK Declaration of Conformity



**Manufacturer:** E. Dold & Söhne GmbH & Co. KG

**Address:** Bregstraße 18  
78120 Furtwangen  
Germany

**Product description:** Emergency Stop Module with voltage failure detection **BH5903.kk/00MF2/ccc** mit: kk = 03, 22  
**BH5903.kk/00vvv/ccc** vvv = 000, 020  
**BL5903.kk/00vvv/ccc** optional ccc = /60 .. /69

The indicated product is in conformance with the regulations of the following British regulations:

**Supply of Machinery (Safety) Regulations:** S.I. 2008 No. 1597

**Electromagnetic Compatibility Regulations:** S.I. 2016 No. 1091

**RoHS Regulations:** S.I. 2012 No. 3032

**Designated standards:** EN ISO 13849-1:2015 EN 60664-1:2007  
EN 62061:2005 + AC:2010 + A1:2013 + A2:2015 EN 61508 Parts 1-7:2010  
EN 61000-6-2:2005 EN 61000-6-4:2007 + A1:2011  
EN 55011:2016 + A1:2017

Consistency of a production sample with the marked product in accordance to the above machinery directive has been certified by:

**Certification office:** TÜV Rheinland UK Ltd., Friars Gate(Third Floor),  
1011 Stratford Road, Shirley, Solihull B90 4BN, United Kingdom  
**Number of certification office:** 2571  
**Certification number:** 01/205U/0760.00/22  
**Date of issue:** 2022-07-29

**For the compilation of technical documents is authorized:** **Signature of authorized person:**

Dold Industries Ltd

11 Hamberts Rd. Blackall Ind. Estate  
South Woodham Ferrers  
GB - Essex, CM3 5UW

.....  
*Christian Dold*  
Christian Dold - Productmanagement

**Place, Date :** Furtwangen, 2022-08-24

This original declaration confirms the conformity of the mentioned directives but does not comprise any guarantee of the product characteristics. The safety directives of the product documentation are to be considered.