

SAFEMASTER
Emergency Stop Module
with time delay
LG 5928

Translation
of the original instructions



E. Dold & Söhne GmbH & Co. KG
 Bregstraße 18 • 78120 Furtwangen • Germany
 Phone: +49 7723 654-0 • Fax +49 7723 654356
 dold-relays@dold.com • www.dold.com

0264221

Contents

Symbol and Notes Statement.....	13
General Notes	13
Designated Use	13
Safety Notes	13
Block Diagram	15
Approvals and Markings	15
Application	15
Indicators	15
Circuit Diagram.....	15
Connection Terminals	16
Notes	16
Technical Data	16
Technical Data	16
UL-Data	17
Standard Type.....	17
Variants.....	17
Troubleshooting	18
Maintenance and repairs.....	18
Characteristics.....	18
Application Examples	19
Remarques	26
Variantes.....	27
Connection Technology	31
Dimensions (dimensions in mm)	32
Mounting / disassembly of the PS / PC-terminal blocks	32
Safety related data (only instantaneous contacts).....	33
Safety related data (only delayed contacts).....	33
CE-Declaration of Conformity	34
Notice	35



Before installing, operating or maintaining this device, these instructions must be carefully read and understood.



Keep instructions for future reference



The installation must only be done by a qualified electrician!



Do not dispose of household garbage!
The device must be disposed of in compliance with nationally applicable rules and requirements.

To help you understand and find specific text passages and notes in the operating instructions, we have important information and information marked with symbols.

Symbol and Notes Statement



DANGER:
Indicates that death or severe personal injury will result if proper precautions are not taken.



WARNING:
Indicates that death or severe personal injury can result if proper precautions are not taken.



CAUTION:
Indicates that a minor personal injury can result if proper precautions are not taken.



INFO:
Referred information to help you make best use of the product.



ATTENTION:
Warns against actions that can cause damage or malfunction of the device, the device environment or the hardware / software result.

General Notes

The product hereby described was developed to perform safety functions as a part of a whole installation or machine. A complete safety system normally includes sensors, evaluation units, signals and logical modules for safe disconnections. The manufacturer of the installation or machine is responsible for ensuring proper functioning of the whole system. DOLD cannot guarantee all the specifications of an installation or machine that was not designed by DOLD. The total concept of the control system into which the device is integrated must be validated by the user. DOLD also takes over no liability for recommendations which are given or implied in the following description. The following description implies no modification of the general DOLD terms of delivery, warranty or liability claims.

Designated Use

The LG 5928 is used to interrupt a safety circuit in a safe way. It can be used to protect people and machines in applications with emergency stop circuits on machines (stop category 1 can be realised) and monitoring of safety gates

When used in accordance with its intended purpose and following these operating instructions, this device presents no known residual risks. Nonobservance may lead to personal injuries and damages to property.

Safety Notes



Risk of electrocution!
Danger to life or risk of serious injuries.

- Disconnect the system and device from the power supply and ensure they remain disconnected during electrical installation.
- The device may only be used for the applications described in the mutually applicable operating instructions / data sheet. The notes in the respective documentation must be heeded. The permissible ambient conditions must be observed.
- The contact protection of the elements connected and the insulation of the supply cables must be designed in accordance with the requirements in the operating instructions / data sheet.
- Note the VDE and local regulations, particularly those related to protective measures.



Risk of fire or other thermal hazards!
Danger to life, risk of serious injuries or property damage.

- The device may only be used for the applications described in the mutually applicable operating instructions / data sheet. The notes in the respective documentation must be heeded. The permissible ambient conditions must be observed. In particular, the current limit curve must be heeded.
- The device may only be installed and put into operation by experts who are familiar with this technical documentation and the applicable health and safety and accident prevention regulations.



Functional error!
Danger to life, risk of serious injuries or property damage.

- The device may only be used for the applications described in the mutually applicable operating instructions / data sheet. The notes in the respective documentation must be heeded. The permissible ambient conditions must be observed.
- The device may only be installed and put into operation by experts who are familiar with this technical documentation and the applicable health and safety and accident prevention regulations.
- The unit should be panel mounted in an enclosure rated at IP 54 or superior. Dust and dampness may lead to malfunction.



Installation fault!
Danger to life, risk of serious injuries or property damage.

- Make sure of sufficient protection circuitry at all output contacts for capacitive and inductive loads.



Attention!

- The safety function must be triggered during commissioning.
- The line fault detection is only active when the time delayed relays K1₁ and K2₁ have released and then S12 (channel A) and S32 (channel B) are switched simultaneously.
- If a line fault occurs after the voltage has been connected to S12, S22, the unit will be activated because this line fault is similar to the normal On-function.
- **AUTOMATIC START !**
According to IEC/EN 60204-1 part 9.2.5.4.2 and 10.8.3 it is not allowed to restart automatically after emergency stop. Therefore the machine control has to disable the automatic start after emergency stop.
- Opening the device or implementing unauthorized changes voids any warranty

SAFEMASTER Emergency Stop Module With Time Delay LG 5928



Your advantage

- Compact, flexible and safe
- Short response time
- Ideal for designs according to the new safety standards

Features

- **According to**
 - Performance Level (PL) e and category 4 to EN ISO 13849-1
 - SIL Claimed Level (SIL CL) 3 to IEC/EN 62061
 - Safety Integrity Level (SIL) 3 to IEC/EN 61508 and IEC/EN 61511
- Output: 2 NO instantaneous contacts and 1 release delay contact
- 1- or 2-channel connection
- Line fault detection at the ON pushbuttons at connection on terminals S33-S34
- Manual restart with button on S33-S34 or automatic restart with bridge between S13-S34
- With or without cross fault monitoring in the E-stop loop
- Indication for released time circuit
- LED indication for supply, channel 1/2 and release delayed contacts
- Wire connection: also 2 x 1.5 mm² stranded ferruled (isolated), DIN 46228-1/-2/-3/-4 or 2 x 2.5 mm² stranded ferruled DIN 46228-1/-2/-3
- As option with pluggable terminal blocks for easy exchange of devices
 - with screw terminals
 - or with cage clamp terminals
- Width 22.5 mm

Function Diagram

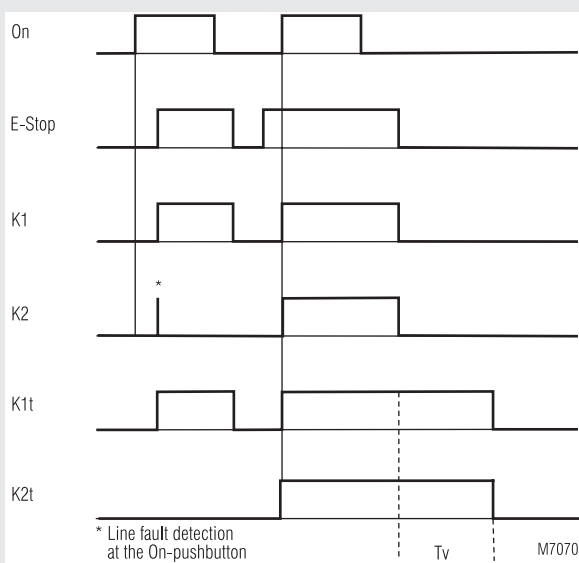

Approvals and Markings



*) See variants

Application

- Protection of people and machines
- Emergency stop circuits on machines, Stop category 1 can be realised
 - Monitoring of safety gates

Block Diagram

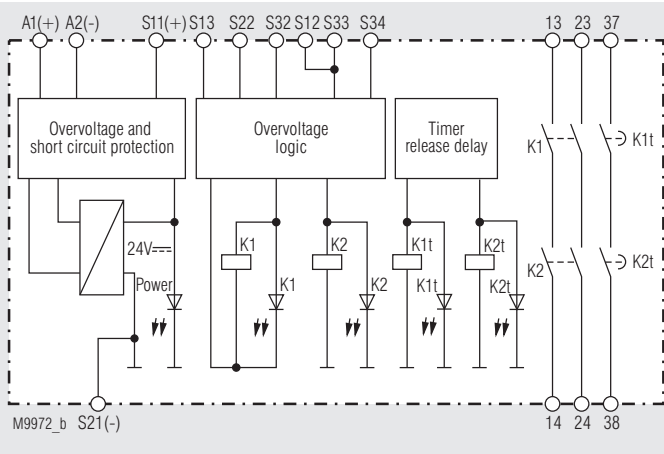

Indicators

- Upper LED: On when supply connected
- Lower LEDs: On, when relay K1 and K2 resp. K1_t and K2_t energized

Circuit Diagram

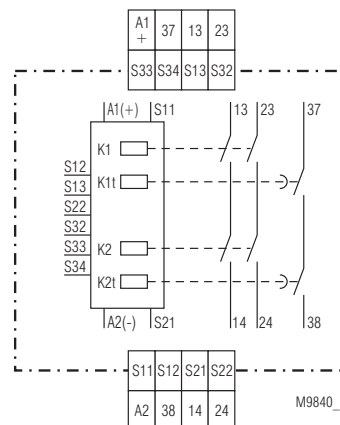

LG 5928.41

Connection Terminals	
Terminal designation	Signal description
A1(+)	+ / L
A2 (-)	- / N
S11, S21, S13, S33	Inputs
S12, S22, S32, S34	Outputs
13, 14, 23, 24	Positive driven NO contacts for release circuit
37, 38	Positive guided No contacts for release delay circuit

Notes

To select automatic restart terminals S13 - S34 must be bridged, S33 - S34 must be opened. Open terminals S13 - S34 select manual restart, the On-button must then be connected to S33 - S34.

Line fault detection on On-button:

The line fault detection is only active when the time delayed relays $K1_1$ and $K2_1$ have released and then S12 (channel A) and S32 (channel B) are switched simultaneously. If the On-button is closed before S12, S32 is connected to voltage (also when line fault across On-button), the output contacts will not close. The unit will not restart before the time delay is finished.

A line fault across the On-button which occurred after activation of the relay, will be detected with the next activation and the output contacts will not close. If a line fault occurs after the voltage has been connected to S12, S32, the unit will be activated because this line fault is similar to the normal On-function.

The unit can be operated with single channel and 2-channel operation with cross fault monitoring. For connection please refer to application examples.

The terminal S21 permits the operation of the device in IT-systems with insulation monitoring, serves as a reference point for testing the control voltage and is used to connect the E-stop loop when cross fault monitoring is selected.

Connecting the terminal S21 to the protective ground bridges the internal short-circuit protection of Line A2(-). The short-circuit protection of line A1(+) remains active.

Technical Data

Input

Nominal voltage U_N:	DC 24 V
Voltage range:	0.9 ... 1.1 U_N
Nominal consumption:	Approx. 3.5 W
Min. Off-time:	1 s
Control voltage S11:	DC 23 V at U_N device not activated
Control current via S12, S32:	each 40 mA at U_N
Min. voltage to terminals S12, S32:	DC 19 V device not activated
Short-circuit protection:	Internal PTC
Overvoltage protection:	Internal VDR

Output

Contacts:	2 NO contacts instantaneous, and 1 contact release delay
------------------	--

Operating time typ. at U_N

Manual start:	25 ms
Automatic start at U_N :	100 ms

Release delay typ. at U_N

in case of break of supply voltage:	20 ms
In case of break of S12, S22 and S32:	10 ms

Technical Data

Time delay tv

(release delayed):

Auxiliary supply must be connected for time delay

Time ranges:

0.1 ... 1 s	3.0 ... 30 s
0.3 ... 3 s	6.0 ... 60 s
0.5 ... 5 s	30 ... 300 s
1.0 ... 10 s	

Other ranges or values on request

± 1 % of setting value

Repeat accuracy:

Contact type:

Nominal output voltage:

forcibly guided

AC 250 V

DC: See arc limit curve

DC: See arc limit curve

Max switching current:

Thermal current I_{th} :

in 1 contact path:

13 / 14 or 23 / 24:

37 / 38:

Max. 8 A (see quadratic total current limit curve)

Max. 6 A (see quadratic total current limit curve)

Switching capacity

to AC 15

NO contact:

3 A / AC 230V

IEC/EN 60947-5-1

To DC 13

NO contacts:

2 A / DC 24 V

Electrical life

to AC 15 at 2 A, AC 230 V:

10⁵ switching cycles IEC/EN 60947-5-1

Permissible operating frequency:

Max. 360 switching cycles / h

with short release delay time

Short circuit strength

max. fuse rating

13 / 14 or 23 / 24:

37 / 38:

Line circuit breaker:

10 A gG / gL

IEC/EN 60947-5-1

4 A gG / gL

IEC/EN 60947-5-1

B 6 A

(max. short circuit current + 300 A)

10 x 10⁶ switching cycles

Mechanical life:

General Data

Operating mode:

Continuous operation

Temperature range

Operation:

- 25 ... + 55 °C

Storage:

- 25 ... + 85 °C

Altitude:

≤ 2000 m

Clearance and creepage distances

Rated impuls voltage /

Pollution degree:

4 kV / 2

IEC 60664-1

EMC

Interference suppression:

IEC/EN 61326-3-1, IEC/EN 62061

Limit value class B

EN 55011

Degree of protection

Housing:

IP 40

IEC/EN 60529

Terminals:

IP 20

IEC/EN 60529

Housing:

Thermoplastic with V0 behaviour

according to UL subject 94

Vibration resistance:

Amplitude 0.35 mm,

frequency 10 ... 55 Hz IEC/EN 60068-2-6

25 / 055 / 04 IEC/EN 60068-1

Climate resistance:

Terminal designation:

EN 50005

Wire fixing:

Plus-minus terminal screws M3.5 box

terminals with wire protection

Mounting:

DIN rail

IEC/EN 60715

Weight:

Approx. 210 g

Dimensions

Width x height x depth:

LG 5928:

22.5 x 90 x 121 mm

LG 5928PC:

22.5 x 111 x 121 mm

LG 5928PS:

22.5 x 104 x 121 mm

UL-Data

The safety functions were not evaluated by UL. Listing is accomplished according to requirements of Standard UL 508, "general use applications"

Nominal voltage U_N : DC 24 V

Ambient temperature: - 15 ... + 55 °C

Switching capacity:
Ambient temperature 45 °C

Contact 13/14 and 23/24:
Pilot duty R300
6A 250Vac Resistive
6A 24Vdc Resistive or G.P.
Contact 37/38:
8A 250Vac Resistive
8A 24Vdc Resistive or G.P.

Ambient temperature 55 °C:

Contact 13/14 and 23/24:
Pilot duty R300
5A 250Vac Resistive
5A 24Vdc Resistive or G.P.
Contact 37/38:
7A 250Vac Resistive
7A 24Vdc Resistive or G.P.

Wire connection: 60 °C / 75 °C copper conductors only
Screw terminals fixed: AWG 20 - 12 Sol/Str Torque 0.8 Nm
Plug in screw: AWG 20 - 14 Sol Torque 0.8 Nm
AWG 20 - 16 Str Torque 0.8 Nm
Plug in cage clamp: AWG 20 - 12 Sol/Str



Technical data that is not stated in the UL-Data, can be found in the technical data section.

Standard Type

LG 5928.41/61 DC 24 V 1 ... 10 s

Article number: 0061683
• Output: 2 NO contacts instantaneous and
• 1 NO contacts release delayed
• Nominal voltage U_N : DC 24 V
• Time delay tv: 1 ... 10 s
• Width: 22.5 mm

Variants

LG 5928.41/61: With redundant time circuits to disconnect K1t and K2t, adjustable time. Each time circuit operates one output relay

LG 5928.41/001/61: As LG 5928.41/61, but with fixed time delay
Fixed times: 1 s, 3 s, 5 s, 10 s, 300 s
other values on request

Ordering example for variants:

LG 5928 .41 / /61 DC 24 V 1 ... 10 s

Fixed times

0.1 ... 1 s

0,3 ... 3 s

0.5 ... 5 s

1 ... 10 s

30 ... 300 s

Nominal voltage U_N

UL-approval

Variant, if required

Type of terminals

Without indication:

Terminal blocks fixed
with screw terminals

PC (plug in cage clamp):

Pluggable terminal blocks
with cage clamp terminals

PS (plug in screw):

Pluggable terminal blocks
with screw terminals

Contacts

Type

Troubleshooting

Failure	Potential cause
LED "Power" does not light up	Power supply A1/A2 not connected
LED "K1" lights up, but "K2" remains off	- Safety relay K1 is welded (replace device) - A 1-channel switch-off occurred on S12 (switch channel off on S22 e. g. S32)
LED "K2" lights up, but "K1" remains off	- Safety relay K2 is welded (replace device) - A 1-channel switch-off occurred on S22 e. g. S32 (switch channel off on S12)
Device cannot be activated	- The delayed contacts are not yet switched off - Safety relay is welded (replace device) - Min. one of this connection is not present (S11-S12, S11-S32, S21-S22) Manual start mode: - Line fault on start-button (disconnect power supply and remove fault) - Automatic start mode: S13-S34 are not bridged

Maintenance and repairs

- The device contains no parts that require maintenance.
- In case of failure, do not open the device but send it to manufacturer for repair.

Characteristics

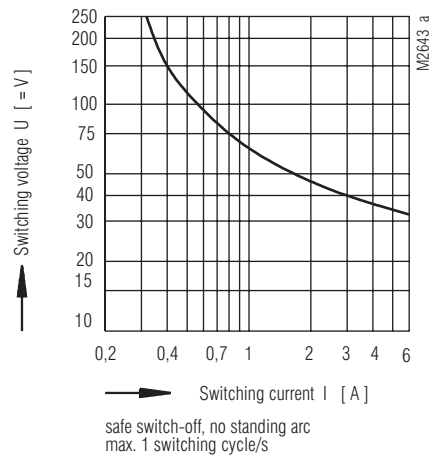

Arc limit curve

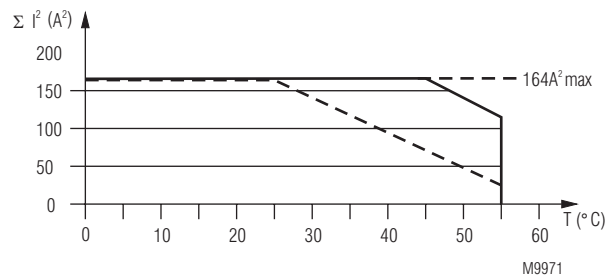

— Device mounted on distance with air circulation.
Max. current at 55°C over
3 contactrows = $2 \times (7A)^2 + (5A)^2 = 123A^2$

- - - Device mounted without distance heated by
devices with same load.
Max. current at 55°C over
3 contactrows = $3 \times (3A)^2 = 27A^2$

$$\Sigma I^2 = I_1^2 + I_2^2 + I_3^2$$

I_1, I_2, I_3 - Current in contactrows

Quadratic total current limit curve

Application Examples

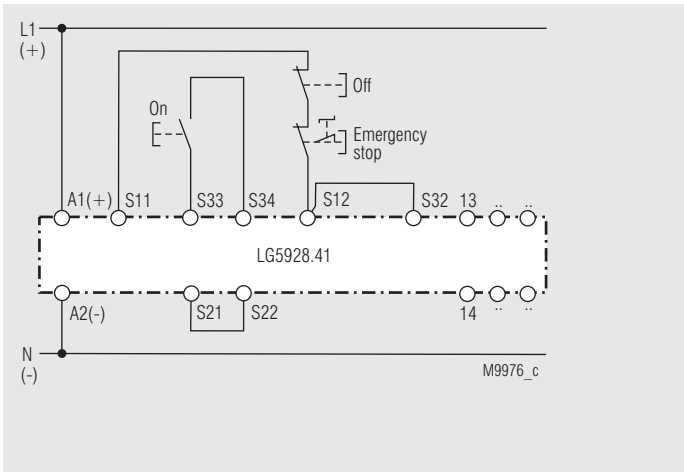

Single channel emergency stop circuit. This circuit does not have any redundancy in the emergency-stop control circuit. Suited up to SIL2, Performance Level d, Cat. 3

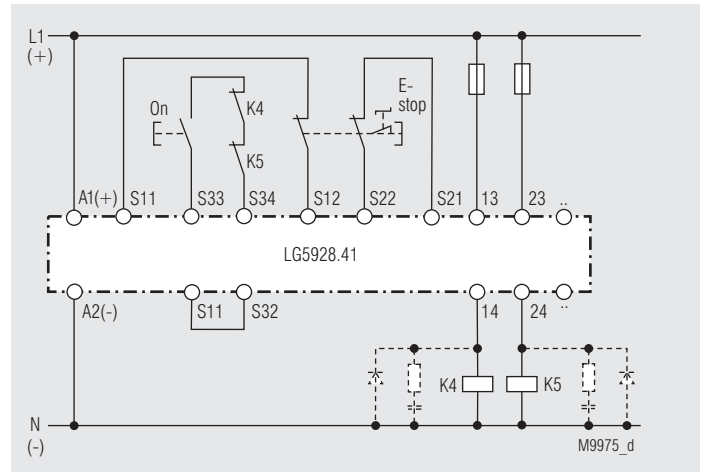

Contact reinforcement by external contactors, 2-channel controlled. The output contacts can be reinforced by external contactors with forcibly guided contacts for switching currents > 8 A e.g. 6 A. Functioning of the external contactors is monitored by looping the NC contacts into the closing circuit (terminals S13-S34 or S33-S34). Suited up to SIL3, Performance Level e, Cat. 4

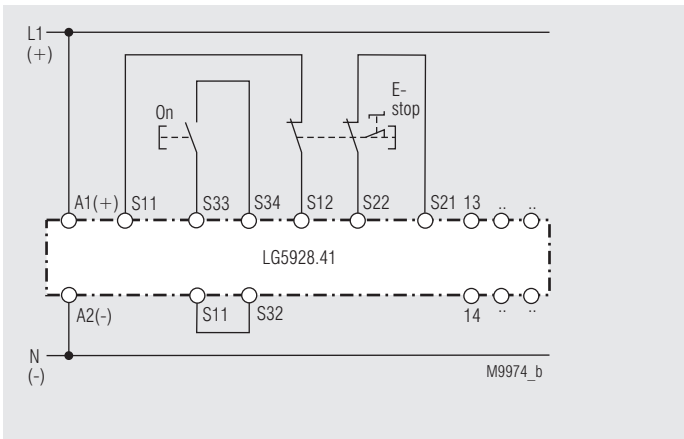

2-channel emergency stop circuit with cross fault monitoring. Suited up to SIL3, Performance Level e, Cat. 4

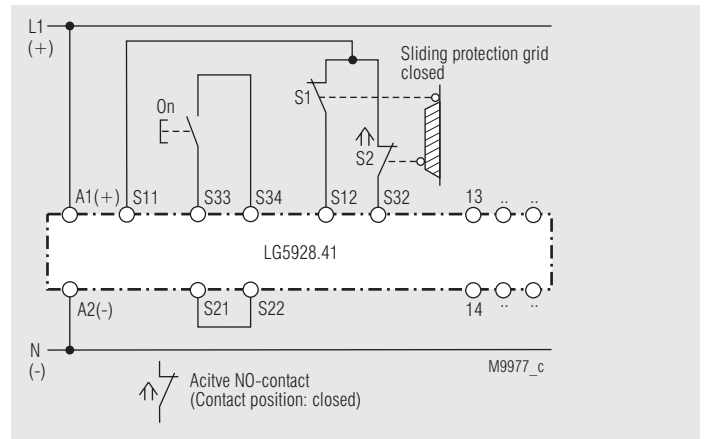

2-channel safety gate monitoring. Suited up to SIL3, Performance Level e, Cat. 4

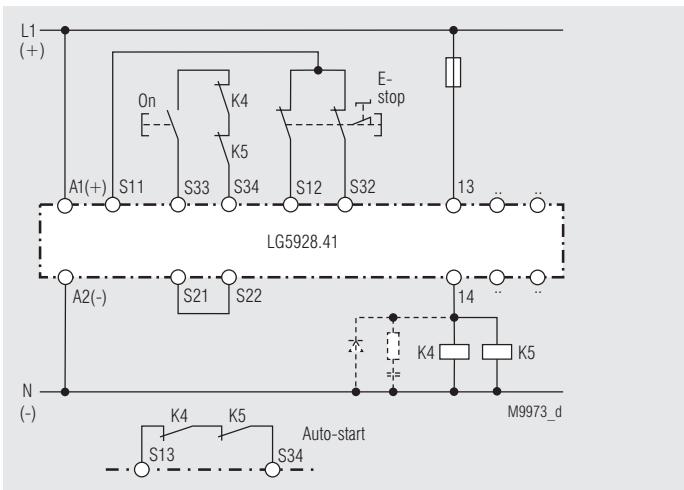

Contact reinforcement by external contactors controlled by one contact path. S33 - S34 must stay open on auto start. Suited up to SIL3, Performance Level e, Cat 4, if the external contactors are in the same cabinet and the wiring is short circuit and crossfault prove.

DE	Anschlussstechnik
EN	Connection Technology
FR	Technologie de connexion

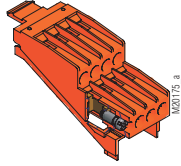
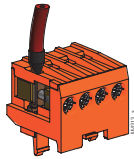
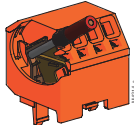
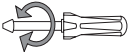
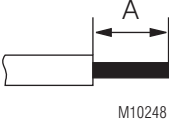
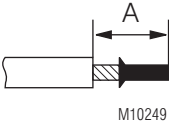
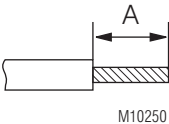
	Schraubklemmen, nicht abnehmbar Screw terminals, fixed Bornes à vis, fixes	Schraubklemmen, abnehmbar Screw terminals, pluggable Bornes à vis, amovibles	Federkraftklemmen, abnehmbar Cage clamp terminals, pluggable Bornes ressorts, amovibles	
		 PS	 PC	
	∅ 4 mm / PZ 1 0,8 Nm 7 LB. IN	∅ 4 mm / PZ 1 0,8 Nm 7 LB. IN	DIN 5264-A; 0,5 x 3	
 M10248	A = 8 mm 1 x 0,5 ... 4 mm ² 1 x AWG 20 to 12 2 x 0,5 ... 2,5 mm ² 2 x AWG 20 to 14	A = 8 mm 1 x 0,5 ... 2,5 mm ² 1 x AWG 20 to 14 2 x 0,5 ... 1,5 mm ² 2 x AWG 20 to 16	A = 10 ... 12 mm 1 x 0,5 ... 2,5 mm ² 1 x AWG 20 to 14	A = 12 mm 1 x 0,5 ... 4 mm ² 1 x AWG 20 to 12
 M10249	A = 8 mm 1 x 0,5 ... 2,5 mm ² 1 x AWG 20 to 14 2 x 0,5 ... 1,5 mm ² 2 x AWG 20 to 16	A = 8 mm 1 x 0,5 ... 2,5 mm ² 1 x AWG 20 to 14 2 x 0,5 ... 1 mm ² 2 x AWG 20 to 18	A = 10 ... 12 mm 1 x 0,5 ... 1,5 mm ² 1 x AWG 20 to 16	A = 12 mm 1 x 0,5 ... 2,5 mm ² 1 x AWG 20 to 14
 M10250	A = 8 mm 1 x 0,5 ... 4 mm ² 1 x AWG 20 to 12 2 x 0,5 ... 2,5 mm ² 2 x AWG 20 to 14	A = 8 mm 1 x 0,5 ... 2,5 mm ² 1 x AWG 20 to 14 2 x 0,5 ... 1,5 mm ² 2 x AWG 20 to 16	A = 10 ... 12 mm 1 x 0,5 ... 2,5 mm ² 1 x AWG 20 to 14	A = 12 mm 1 x 0,5 ... 4 mm ² 1 x AWG 20 to 12

DE	Maßbild (Maße in mm)
EN	Dimensions (dimensions in mm)
FR	Dimensions (dimensions en mm)

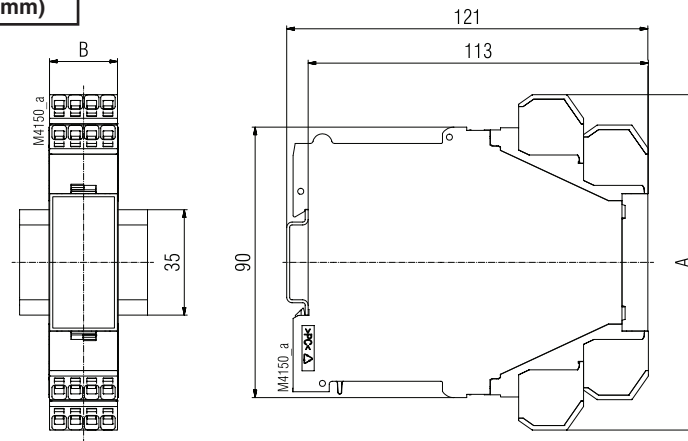

	A	B
LG 5928	90	22,5
LG 5928 PS	104	22,5
LG 5928 PC	111	22,5

DE	Montage / Demontage der PS / PC-Klemmenblöcke
EN	Mounting / disassembly of the PS / PC-terminal blocks
FR	Montage / Démontage des borniers PS / PC

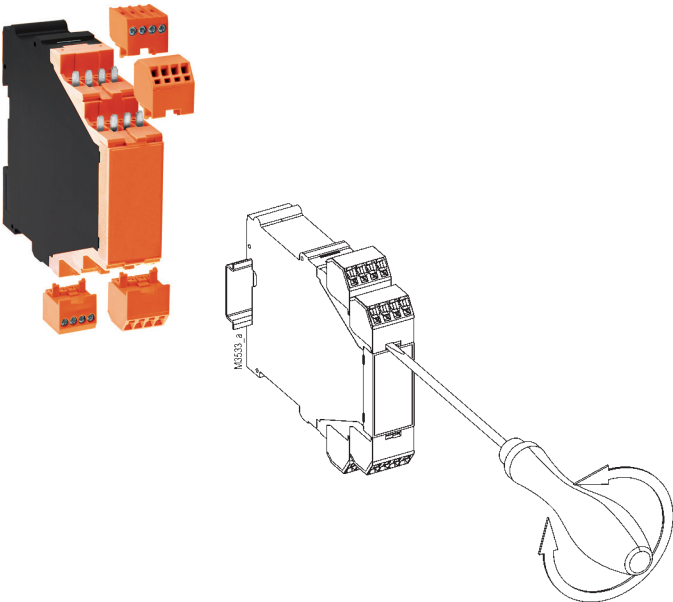

DE	Demontage der steckbaren Klemmenblöcke (Stecker) <ol style="list-style-type: none"> Gerät spannungsfrei schalten. Schraubendreher in die frontseitige Aussparung zwischen Stecker und Frontplatte hineinschieben. Schraubendreher um seine Längsachse drehen. Beachten Sie bitte, dass die Klemmenblöcke nur auf dem zugehörigen Steckplatz montiert werden.
EN	Removing the terminal blocks with cage clamp terminals <ol style="list-style-type: none"> The unit has to be disconnected. Insert a screwdriver in the side recess of the front plate. Turn the screwdriver to the right and left. Please note that the terminal blocks have to be mounted on the belonging plug in terminations.
FR	Démontage des borniers amovibles <ol style="list-style-type: none"> Mise hors tension de l'appareil Enfoncer un tourne-vis dans la fente entre la face avant et le bornier Tourner le tourne-vis pour libérer le bornier Tenir compte du fait que les borniers ne doivent être montés qu'à leur place appropriée

DE	Sicherheitstechnische Kenndaten (nur Sofortkontakte)
EN	Safety related data (only instantaneous contacts)
FR	Données techniques sécuritaires (contact instantané)

DE	Sicherheitstechnische Kenndaten (nur verzögerte Kontakte)
EN	Safety related data (only delayed contacts)
FR	Données techniques sécuritaires (contact retardée)

EN ISO 13849-1:		
Kategorie / Category:	4	
PL:	e	
MTTF _d :	351,8	a (year)
DC _{avg} :	99,0	%
d _{op} :	365	d/a (days/year)
h _{op} :	24	h/d (hours/day)
t _{cycle} :	3600	s/cycle
	≥ 1	/h (hour)

EN ISO 13849-1:		
Kategorie / Category:	3	
PL:	d	
MTTF _d :	495,4	a (year)
DC _{avg} :	97,3	%
d _{op} :	365	d/a (days/year)
h _{op} :	24	h/d (hours/day)
t _{cycle} :	3600	s/cycle
	≥ 1	/h (hour)

IEC/EN 62061 IEC/EN 61508 IEC/EN 61511:		
SIL CL:	3	IEC/EN 62061
SIL:	3	IEC/EN 61508 / IEC/EN 61511
HFT ¹⁾ :	1	
DC:	99,0	%
PFH _D :	1,37E-10	h ⁻¹
T ₁ :	20	a (year)
¹⁾ HFT = Hardware-Fehlertoleranz Hardware failure tolerance Tolérance défauts Hardware		

IEC/EN 62061 IEC/EN 61508 IEC/EN 61511:		
SIL CL:	2	IEC/EN 62061
SIL:	2	IEC/EN 61508 / IEC/EN 61511
HFT ¹⁾ :	1	
DC:	97,3	%
PFH _D :	2,76E-10	h ⁻¹
T ₁ :	20	a (year)
¹⁾ HFT = Hardware-Fehlertoleranz Hardware failure tolerance Tolérance défauts Hardware		



DE	Die angeführten Kenndaten gelten für die Standardtype. Sicherheitstechnische Kenndaten für andere Geräteausführungen erhalten Sie auf Anfrage. Die sicherheitstechnischen Kenndaten der kompletten Anlage müssen vom Anwender bestimmt werden.
EN	The values stated above are valid for the standard type. Safety data for other variants are available on request. The safety relevant data of the complete system has to be determined by the manufacturer of the system.
FR	Les valeurs données sont valables pour les produits standards. Les valeurs techniques sécuritaires pour d'autres produits spéciaux sont disponibles sur simple demande. Les données techniques sécuritaires de l'installation complète doivent être définies par l'utilisateur.

Anforderung seitens der Sicherheitsfunktion an das Gerät Demand to our device based on the evaluated necessary safety level of the application. Consigne résultant de la fonction sécuritaire de l'appareil	Intervall für zyklische Überprüfung der Sicherheitsfunktion Intervall for cyclic test of the safety function Interval du contrôle cyclique de la fonction sécuritaire
nach, acc. to, selon EN ISO 13849-1	PL e with Cat. 3 or Cat. 4 einmal pro Monat once per month mensuel
	PL d with Cat. 3 einmal pro Jahr once per year annuel
nach, acc. to, selon IEC/EN 62061, IEC/EN 61508	SIL CL 3, SIL 3 with HFT = 1 einmal pro Monat once per month mensuel
	SIL CL 2, SIL 2 with HFT = 1 einmal pro Jahr once per year annuel
nach, acc. to, selon EN 61511	SIL 3 einmal pro Jahr once per year annuel

DE	EG-Konformitätserklärung
EN	CE-Declaration of Conformity
FR	Déclaration de conformité européenne

EG - Konformitätserklärung
Declaration of Conformity
Déclaration de conformité européenne



Hersteller: E. Dold & Söhne GmbH & Co. KG
Manufacturer: / Fabricant:
Anschrift: Bregstraße 18
Address: / Adresse: 78120 Furtwangen
Germany

Produktbezeichnung: Not-Aus-Modul **LG5928.kkccc** mit: kk = 41
Product description: Emergency-stop-module **LG5928.kkttccc** *with:* tt = PS, PC
optional ccc = /60 .. /69
Désignation du produit: Module arrêt d'urgence *avec:*

Das bezeichnete Produkt stimmt mit den Vorschriften folgender europäischer Richtlinien überein:
The indicated product is in conformance with the regulations of the following european directives:
Le produit désigné est conforme aux instructions des directives européennes:

Maschinenrichtlinie: 2006/42/EG EU-Abl. L157/24, 09.06.2006
Machinery directive: / Directives Machines:
EMV - Richtlinie: 2014/30/EU EU-Abl. L96/79, 29.03.2014
EMC - Directive: / Directives- CEM.:
RoHS - Richtlinie 2011/65/EU EU-Abl. L174/88, 01.07.2011
RoHS -Directive: / Directives - RoHS:

Prüfgrundsätze: EN ISO 13849-1:2015 EN 61508 Parts 1, 2:2010
Basis of Testing: EN 62061:2015 EN 61511-1:2017
Lignes de contrôle: EN 61000-6-1:2007 EN 61000-6-2:2005
EN 61000-6-3:2007 + A1:2011 EN 61000-6-4:2007 + A1:2011

Die Übereinstimmung eines Baumusters des bezeichneten Produktes mit der oben genannten Maschinenrichtlinie wurde bescheinigt durch:

Consistency of a production sample with the marked product in accordance to the above machiney directive has been certified by:
La conformité d'un échantillon du produit désigné aux directives machines susmentionnées a été certifiée par:

Benannte Stelle: TÜV Süd Product Service GmbH
Certification office: / l'organisme notifié: Ridlerstraße 65, 80339 München
0123

Numer der benannten Stelle:
Number of certification office: / Numéro de l'organisme notifié: Z10 040066 0003

Numer der Bescheinigung:
Certification number: / Numéro de certificat: 22.11.2018

Aussteldatum :
Date of issue: / Date de délivrance:

Für die Zusammenstellung der technischen Unterlagen ist bevollmächtigt:

*For the compilation of technical documents is authorized:
Pour la composition des documents techniques est autorisé:*

Gamal Hagar, Entwicklungsleiter / R&D Manager

Rechtsverbindliche Unterschrift:

*Signature of authorized person:
Signature autorisée :*

Christian Dold, Produktmanagment

Ort, Datum : Furtwangen, 25.06.2021
Place, Date: / Lieu, date:

Diese Original - Erklärung bescheinigt die Übereinstimmung mit den genannten Richtlinien, beinhaltet jedoch keine Zusicherung von Eigenschaften. Die Sicherheitshinweise der Produktdokumentation sind zu beachten.

This original declaration confirms the conformity of the mentioned directives but does not comprise any guarantee of the product characteristics. The safety directives of the product documentation are to be considered.

Cette déclaration originale certifie la conformité des directives nommées mais ne comprend aucune garantie des caractéristiques du produit. Les directives de sécurité de la documentation du produit sont à considérer.

DE	Notizen
EN	Notice
FR	Note

A large grid of graph paper with a dotted horizontal line for writing. The grid consists of 20 columns and 30 rows. The dotted line is positioned approximately 10% of the way down from the top of the grid.

A series of horizontal lines for writing, consisting of 30 lines spaced evenly down the page.

