

SAFEMASTER
Emergency Stop Module
LG 5925

Translation
of the original instructions

0262658



E. Dold & Söhne GmbH & Co. KG
 Bregstraße 18 • 78120 Furtwangen • Germany
 Phone: +49 7723 654-0 • Fax +49 7723 654356
 dold-relays@dold.com • www.dold.com

Contents

Symbol and Notes Statement.....	13
General Notes	13
Designated Use	13
Safety Notes	13
Function Diagram	15
Block Diagrams	15
Approvals and Markings	15
Applications	15
Indicators	15
Circuit Diagrams	16
Connection Terminals	16
Notes	16
Technical Data	16
Technical Data	17
UL-Data	17
Standard Type.....	17
Ordering Example	17
Troubleshooting	18
Maintenance and Repairs.....	18
Characteristics.....	18
Characteristics.....	18
Application Examples	19
Application Examples	20
Connection Technology	31
Dimensions (dimensions in mm)	32
Setting	32
Mounting / disassembly of the PS / PC-terminal blocks	32
Safety Related Data	33
CE-Declaration of Conformity.....	34
UK-Declaration of Conformity.....	35



Before installing, operating or maintaining this device, these instructions must be carefully read and understood.



Keep instructions for future reference



The installation must only be done by a qualified electrician!



Do not dispose of household garbage!
The device must be disposed of in compliance with nationally applicable rules and requirements.

To help you understand and find specific text passages and notes in the operating instructions, we have important information and information marked with symbols.

Symbol and Notes Statement



DANGER:
Indicates that death or severe personal injury will result if proper precautions are not taken.



WARNING:
Indicates that death or severe personal injury can result if proper precautions are not taken.



CAUTION:
Indicates that a minor personal injury can result if proper precautions are not taken.



INFO:
Referred information to help you make best use of the product.



ATTENTION:
Warns against actions that can cause damage or malfunction of the device, the device environment or the hardware / software result.

General Notes

The product hereby described was developed to perform safety functions as a part of a whole installation or machine. A complete safety system normally includes sensors, evaluation units, signals and logical modules for safe disconnections. The manufacturer of the installation or machine is responsible for ensuring proper functioning of the whole system. DOLD cannot guarantee all the specifications of an installation or machine that was not designed by DOLD. The total concept of the control system into which the device is integrated must be validated by the user. DOLD also takes over no liability for recommendations which are given or implied in the following description. The following description implies no modification of the general DOLD terms of delivery, warranty or liability claims.

Designated Use

The LG 5925 is used to interrupt a safety circuit in a safe way. It can be used to protect people and machines in applications with e-stop buttons and safety gates.

When used in accordance with its intended purpose and following these operating instructions, this device presents no known residual risks. Non-observance may lead to personal injuries and damages to property.

Safety Notes



Risk of electrocution! **Danger to life or risk of serious injuries.**

- Disconnect the system and device from the power supply and ensure they remain disconnected during electrical installation.
- The device may only be used for the applications described in the mutually applicable operating instructions / data sheet. The notes in the respective documentation must be heeded. The permissible ambient conditions must be observed.
- The contact protection of the elements connected and the insulation of the supply cables must be designed in accordance with the requirements in the operating instructions / data sheet.
- Note the VDE and local regulations, particularly those related to protective measures.



Risk of fire or other thermal hazards! **Danger to life, risk of serious injuries or property damage.**

- The device may only be used for the applications described in the mutually applicable operating instructions / data sheet. The notes in the respective documentation must be heeded. The permissible ambient conditions must be observed. In particular, the current limit curve must be heeded.
- The device may only be installed and put into operation by experts who are familiar with this technical documentation and the applicable health and safety and accident prevention regulations.



Functional error! **Danger to life, risk of serious injuries or property damage.**

- The device may only be used for the applications described in the mutually applicable operating instructions / data sheet. The notes in the respective documentation must be heeded. The permissible ambient conditions must be observed.
- The device may only be installed and put into operation by experts who are familiar with this technical documentation and the applicable health and safety and accident prevention regulations.
- The unit should be panel mounted in an enclosure rated at IP 54 or superior. Dust and dampness may lead to malfunction.



Installation fault! **Danger to life, risk of serious injuries or property damage.**

- Make sure of sufficient protection circuitry at all output contacts for capacitive and inductive loads.



Attention!

- The safety function must be triggered during commissioning.
- If a line fault occurs after the voltage has been connected to S12, S22, the unit will be activated because this line fault is similar to the normal On-function.
- Switch S1 must not be set while device is under supply voltage.
- **AUTOMATIC START !**
According to IEC/EN 60204-1 part 9.2.5.4.2 and 10.8.3 it is not allowed to restart automatically after emergency stop. Therefore the machine control has to disable the automatic start after emergency stop.
- Opening the device or implementing unauthorized changes voids any warranty

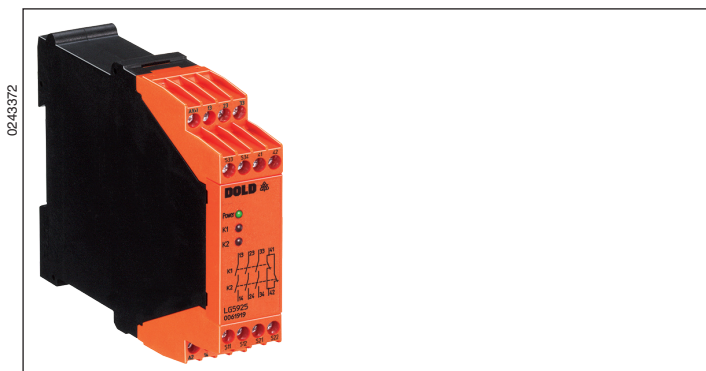

- According to
 - Performance Level (PL) e and category 4 to EN ISO 13849-1
 - SIL Claimed Level (SIL CL) 3 to IEC/EN 62061
 - Safety Integrity Level (SIL) 3 to IEC/EN 61508 and IEC/EN 61511
- According to EN 50156-2 for furnaces
- Output: Max. 4 NO contacts, see contacts
- LG 5925.54: 1 semiconductor output
- Single and 2-channel operation
- Line fault detection on On-button
- Manual restart or automatic restart, switch S2
- With or without cross fault monitoring in the E-stop loop, switch S1
- LG 5925.54: With cross fault monitoring in the E-stop loop
- LED indicator for channel 1, 2 and supply voltage
- Removable terminal strips
- Wire connection: Also 2 x 1.5 mm² stranded ferruled, or 2 x 2.5 mm² solid DIN 46228-1/-2/-3/-4
- As option with pluggable terminal blocks for easy exchange of devices
 - With screw terminals
 - Or with cage clamp terminals
- Width: 22.5 mm

Function Diagram

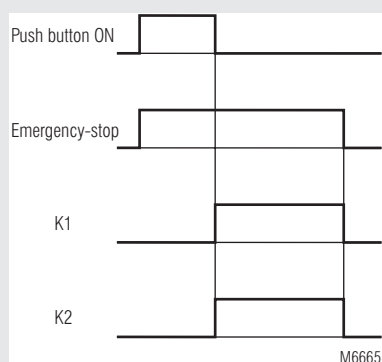

Approvals and Markings



Applications

- Protection of people and machines
- Emergency stop circuits on machines
 - Monitoring of safety gates
 - Usage in furnace application in continuous operation acc. to EN 50156-1
 - Safe disconnection of the complete fuel supply in furnace applications according to EN 50156-1 section 10.5.5.2

Indicators

- LED Power: On when supply connected
- LED K1/K2: On when relay K1 and K2 energized

Block Diagrams

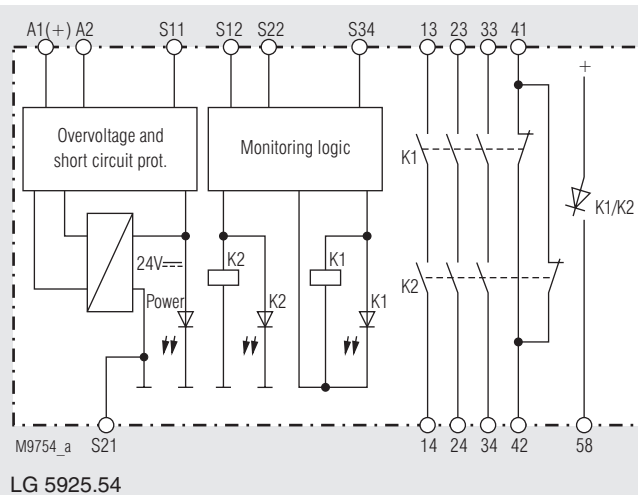
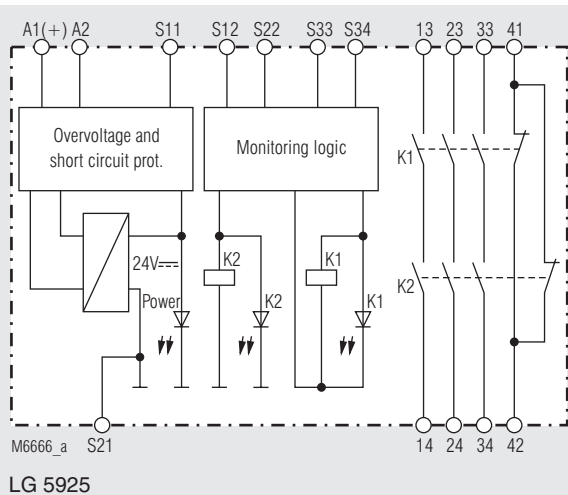

Circuit Diagrams

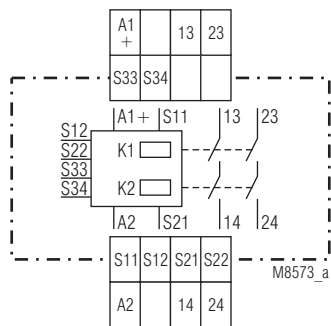

LG 5925.02

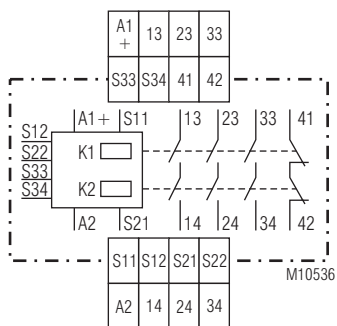

LG 5925.03

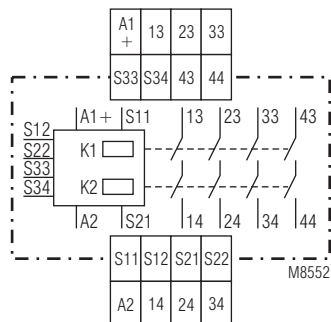

LG 5925.04

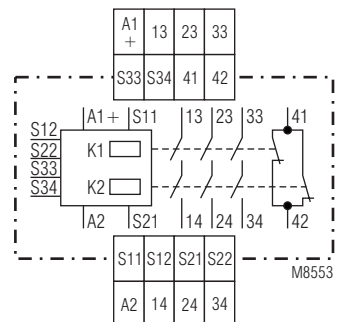

LG 5925.48

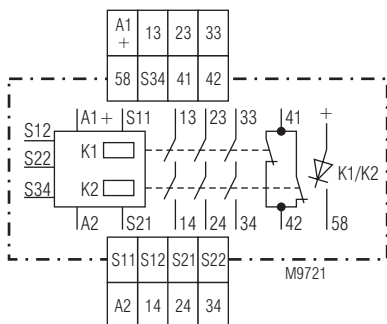

LG 5925.54

Connection Terminals

Terminal designation	Signal description
A1+	+ / L
A2	- / N
S12, S22, S33, S34	Inputs
S11, S21	Outputs
13, 14, 23, 24, 33, 34, 43, 44	Forcibly guided NO contacts for release circuit
41, 42	Forcibly guided indicator output

Notes

Line fault detection on On-button:

The line fault detection is only active when S12 and S22 are switched simultaneously. If The On-button is closed before S12, S22 is connected to voltage (also when line fault across On-Button), the output contacts will not close. A line fault across the On-button which occurred after activation of the relay, will be detected with the next activation and the output contacts will not close.

The terminal S21 permits the operation of the device in IT-systems with insulation monitoring, serves as a reference point for testing the control voltage and is used to connect the E-stop loop when cross fault monitoring is selected.

Connecting the terminal S21 to the protective ground bridges the internal short-circuit protection of Line A2 (-). The short-circuit protection of line A1 (+) remains active.

To alter the functions automatic start - manual start and with or without cross fault monitoring, the switches S1 and S2 are used. These are located behind the front cover (see unit programming).

The setting with or without cross fault monitoring on E-stop buttons is made with S1 (not for LG 5925.54). The LG 5925.54 has always cross fault monitoring.

S2 is used to change between automatic an manual restart. On automatic start also the terminals S33 - S34 have to be linked. For connection please see application examples.

Technical Data

Input circuit

Nominal Voltage U_N :

LG 5925: AC/DC 24 V, AC 110 ... 115 V, AC 230 V
 LG 5925.54: AC/DC 24 V

Voltage range

AC / DC
 at 10% residual ripple: 0.9 ... 1.1 U_N
 AC: 0.85 ... 1.1 U_N
 DC approx. 1.5 W
 AC approx. 3.7 VA

Nominal consumption at U_N :

250 ms
 DC 22 V at AC/DC units
 DC 24 V at AC units

Control current typ. over

S12, S22:
 LG 5925: 30 mA at U_N
 LG 5925.54: 25 mA at U_N

Min. voltage on S12, S22

when relay activated: DC 20 V at AC/DC units
 DC 19 V at AC units

Short-circuit protection:

Internal PTC

Oversvoltage protection:

Internal VDR

Output

Contacts

LG 5925.02: 2 NO contacts
 LG 5925.04: 4 NO contact
 LG 5925.03 ,
 LG 5925.48, LG 5925.54: 3 NO, 1 NC contact

The NO contacts are safety contacts.

The NC contacts 41-42 can only be used for monitoring.

Operate delay typ. at U_N :

Manual start: 30 ms
 Automatic start: 350 ms

Release delay typ. at U_N :

Disconnecting the supply: 150 ms at AC units
 50 ms at DC units
 Disconnecting S12, S22: 130 ms at AC units
 50 ms at DC units

Contact type:

Nominal output voltage:

Forcibly guided
 AC 250 V
 DC: See arc limit curve

Thermal current I_{th} :

Max. 8 A per contact
 see quadratic total current limit curve

Technical Data

Switching capacity

to AC 15:

NO contacts: 3 A / AC 230 V IEC/EN 60947-5-1
 NC contacts: 2 A / AC 230 V IEC/EN 60947-5-1

to DC 13:

NO contacts: 2 A / DC 24 V IEC/EN 60947-5-1
 NC contacts: 2 A / DC 24 V IEC/EN 60947-5-1

to DC 13:

NO contact: 4 A / DC 24 V at 0.1 Hz

NC contact: 4 A / DC 24 V at 0.1 Hz

Electrical contact life

to 5 A, AC 230 V $\cos \varphi = 1$: $> 2.2 \times 10^5$ switching cycles

Permissible operating frequency:

Max. 1200 operating cycles / h

Short circuit strength

max. fuse rating: 10 A gG / gL IEC/EN 60947-5-1

Line circuit breaker: B 6 A

Mechanical life: $> 20 \times 10^6$ switching cycles

Semiconductor output 58: DC 24 V 100 mA, plus switching

General Data

Operating mode: Continuous operation

Temperature range

Operation: - 25 ... + 60 °C
 (see quadratic total current limit curve)
 At an altitude of > 2000 m the maximum permissible temperature reduces by 0.5 °C / 100 m
 Storage: - 40 ... + 85 °C

Storage:

Altitude,

Clearance and creepage distances

Rated impuls voltage / pollution degree:

IEC 60664-1
 ≤ 2000 m > 2000 m up to ≤ 4000 m
 4 kV / 2 2.5 kV / 2

EMC

Interference suppression: EN 61326-3-1, EN 61000-6-7

Degree of protection

Housing: IP 40 IEC/EN 60529

Terminals: IP 20 IEC/EN 60529

Housing:

Thermoplastic with V0 behaviour

according to UL subject 94

Vibration resistance:

Amplitude 0.35 mm IEC/EN 60068-2-6

frequency 10 ... 55 Hz

Climate resistance:

25 / 060 / 04 IEC/EN 60068-1

Terminal designation:

EN 50005

Wire fixing:

Plus-minus terminal screws M 3.5
 box terminals with wire protection or cage clamp terminals

Mounting:

DIN rail IEC/EN 60715

Weight:

LG 5925, AC/DC 24 V: 210 g

LG 5925.54, AC/DC 24 V: 220 g

LG 5925, AC 230 V: 275 g

LH 5925, AC/DC 24 V: 375 g

Dimensions

Width x height x depth:

LG 5925: 22.5 x 90 x 121 mm

LG 5925 PC: 22.5 x 111 x 121 mm

LG 5925 PS: 22.5 x 104 x 121 mm

UL-Data

The safety functions were not evaluated by UL. Listing is accomplished according to requirements of Standard UL 508, "general use applications"

Nominal voltage U_N :

LG 5925.02, .03, .04, .48, .54: AC/DC 24 V, AC 110 ... 115 V
 AC 230 V

Ambient temperature

LG 5925.02, .03, .04, .48, .54: - 25 ... + 55 °C

Altitude:

≤ 2000 m

Switching capacity:

LG 5925.04

Ambient temperature 35 °C: Pilot duty B300
 8A 250Vac Resistive
 8A 24Vdc Resistive or G.P.

LG 5925.04

Ambient temperature 55 °C: Pilot duty B300
 4A 250Vac Resistive
 4A 24Vdc Resistive or G.P.

Switching capacity:

LG 5925.02, .03, .48, .54

Ambient temperature 45 °C: Pilot duty B300
 8A 250Vac Resistive
 8A 24Vdc Resistive or G.P.

LG 5925.02, .03, .48, .54

Ambient temperature 55 °C: Pilot duty B300
 6A 250Vac Resistive
 6A 24Vdc Resistive or G.P.

Wire connection:

60 °C / 75 °C copper conductors only

Screw terminals fixed: AWG 20 - 12 Sol/Str Torque 0.8 Nm

Plug in screw: AWG 20 - 14 Sol Torque 0.8 Nm

AWG 20 - 16 Str Torque 0.8 Nm

Plug in cage clamp: AWG 20 - 12 Sol/Str

Info Technical data that is not stated in the UL-Data, can be found in the technical data section.

Standard Type

LG 5925.48/61 AC/DC 24 V

Article number: 0061919

LG 5925.54/61 AC/DC 24 V

Article number: 0064882

• Output: 3 NO contacts, 1 NC contact

• Nominal voltage U_N : AC/DC 24 V

• Width: 22.5 mm

Ordering Example

LG 5925 / /61 AC 230 V

Nominal voltage
 UL-approval
 Without designation:
 Standard
 CO (on request):
 With partially laquered solder side of the PCB
 Type of terminals
 Without indication:
 Terminal blocks fixed with screw terminals
 PC (plug in cage clamp):
 Pluggable terminal blocks with cage clamp terminals
 PS (plug in screw):
 Pluggable terminal blocks with screw terminals
 Contacts
 Type

Troubleshooting

Failure	Potential cause
LED "Power" does not light up	- Power supply not connected - Cross fault between S11 and S21
LED "K1" lights up, but "K2" remains off	- Safety relay K1 is welded (replace device) - A 1-channel switch-off occurred on S12 (switch channel off on S22)
LED "K2" lights up, but "K1" remains off	- Safety relay K2 is welded (replace device) - A 1-channel switch-off occurred on S22 (switch channel off on S12)
Device cannot be activated	Manual start mode: - Line fault on start-button (disconnect power supply and remove fault) Automatic start mode: - S33-S34 not bridged - A safety relay is welded (replace device) - Incorrect setting of switch S1

Maintenance and Repairs

- The device contains no parts that require maintenance.
- In case of failure, do not open the device but send it to manufacturer for repair.

Characteristics

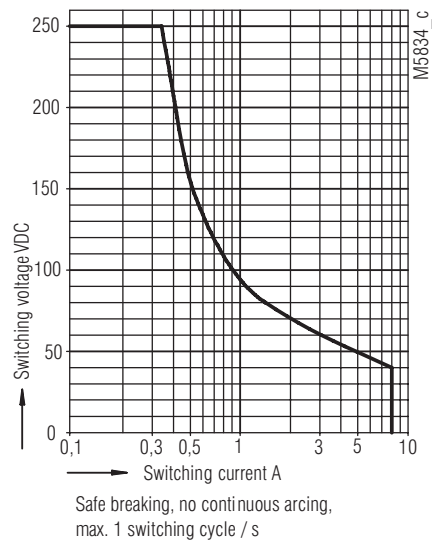

Arc limit curve under resistive load

Characteristics

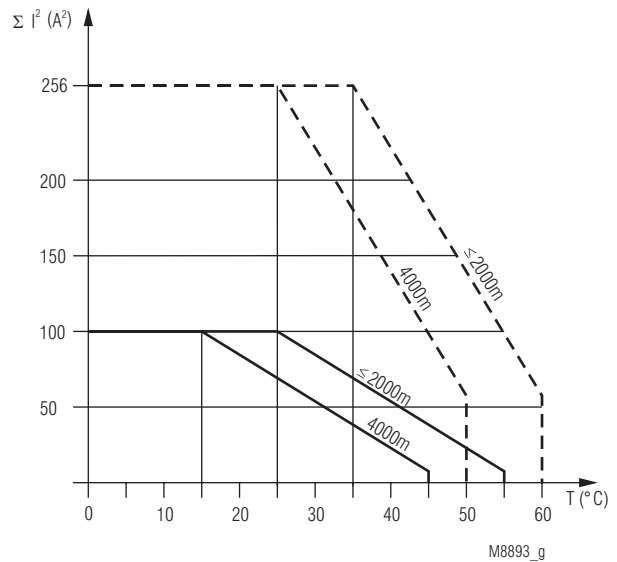

--- Device mounted away from heat generation components.
Max. current at 60°C (≤2000m) or 50°C (4000m) over 4 contact path = 3,8A $\cong 4 \times 3,8^2 \text{A}^2 = 58 \text{A}^2$

— Device mounted without distance heated by devices with same load.
Max. current at 55°C (≤2000m) or 45°C (4000m) over 4 contact path = 1A $\cong 4 \times 1^2 \text{A}^2 = 4 \text{A}^2$

$$\Sigma I^2 = I_1^2 + I_2^2 + I_3^2 + I_4^2$$

I_1, I_2, I_3, I_4 - Current in contact paths

Quadratic total current limit curve LG 5925; AC/DC 24 V

From an altitude of > 2000 m the curve is adjusted by -0.5 °C / 100 m (see example for 4000 m).

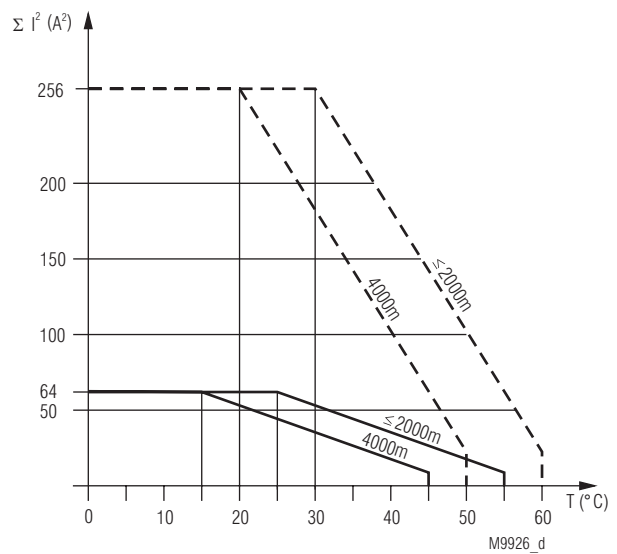

--- Device mounted away from heat generation components.
Max. current at 60°C (≤2000m) or 50°C (4000m) over 4 contact path = 2,4A $\cong 4 \times 2,4^2 \text{A}^2 = 23 \text{A}^2$

— Device mounted with 5mm distance.
Max. current at 55°C (≤2000m) or 45°C (4000m) over 4 contact path = 1A $\cong 4 \times 1^2 \text{A}^2 = 4 \text{A}^2$

$$\Sigma I^2 = I_1^2 + I_2^2 + I_3^2 + I_4^2$$

I_1, I_2, I_3, I_4 - Current in contact paths

Quadratic total current limit curve LG 5925; AC 110 ... 115 V, AC 230 V

From an altitude of > 2000 m the curve is adjusted by -0.5 °C / 100 m (see example for 4000 m).

Application Examples

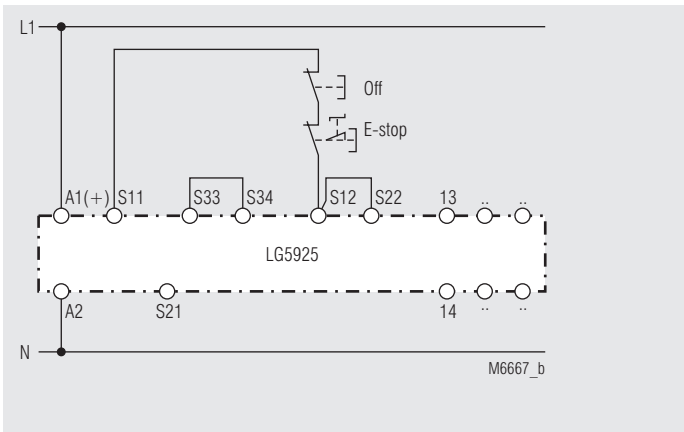

Single channel emergency stop circuit. This circuit does not have any redundancy in the emergency-stop control circuit.

Note: Refer to "Unit programming"!

Switches in pos.: S1 no cross fault detection
S2 automatic start

Suited up to SIL2, Performance Level d, Cat. 3

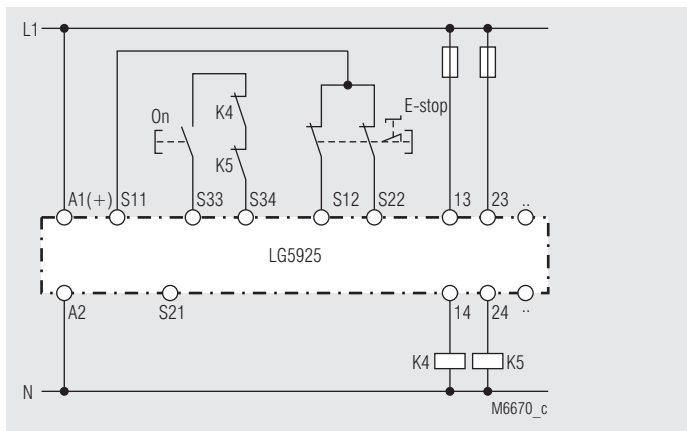

Contact reinforcement by external contactors, 2-channel controlled.

The output contacts can be reinforced by external contactors with forcibly guided contacts for switching currents > 8 A.

Functioning of the external contactors is monitored by looping the NC contacts into the closing circuit (terminals S33-S34).

Note: Refer to "Unit programming"!

Switches in pos.: S1 no cross fault detection
S2 manual start

Suited up to SIL3, Performance Level e, Cat. 4

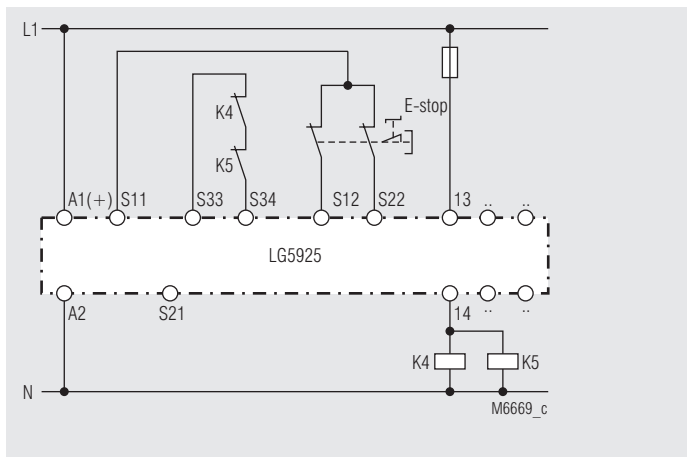

Contact reinforcement by external contactors controlled by one contact path.

Note: Refer to "Unit programming"!

Switches in pos.: S1 no cross fault detection
S2 automatic start

Suited up to SIL3, Performance Level e, Cat. 4

Application Examples

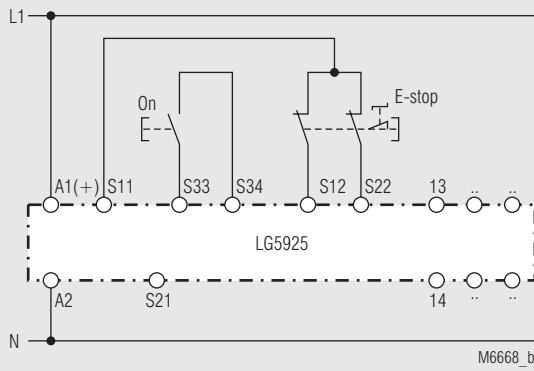

2-channel emergency stop circuit without cross fault monitoring.

Note: Refer to "Unit programming"!

Switches in pos.: S1 no cross fault detection
S2 manual start

Suited up to SIL3, Performance Level e, Cat. 4

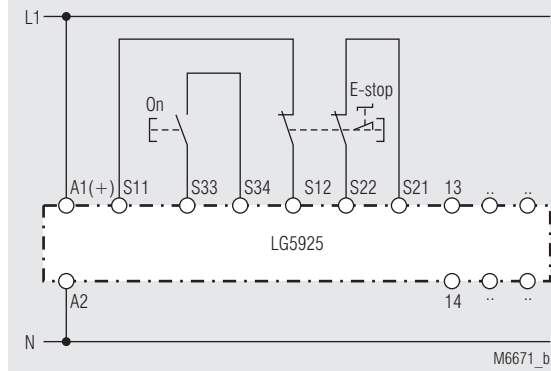

2-channel emergency stop circuit with cross fault detection

Note: Refer to "Unit programming"!

Switches in pos.: S1 cross fault detection
S2 manual start

Suited up to SIL3, Performance Level e, Cat. 4

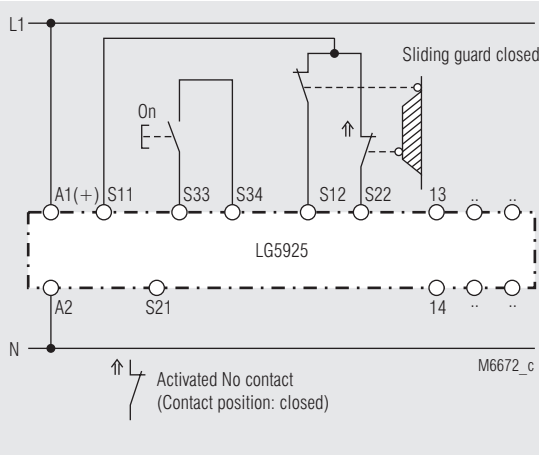

2-channel safety gate monitoring.

Note: Refer to "Unit programming"!

Switches in pos.: S1 no cross fault detection
S2 manual start

Suited up to SIL3, Performance Level e, Cat. 4

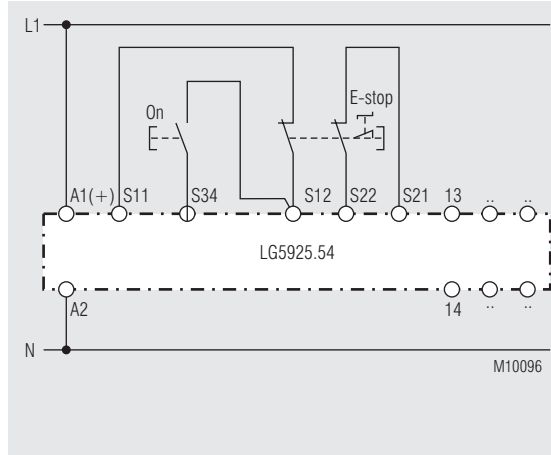

2-channel emergency stop circuit with cross fault detection

Note: Refer to "Unit programming"!

Switches in pos.: S2 manual start

Suited up to SIL3, Performance Level e, Cat. 4

DE	Anschlussstechnik
EN	Connection Technology
FR	Technologie de connexion

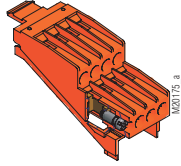
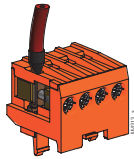
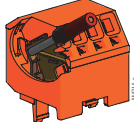
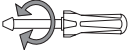
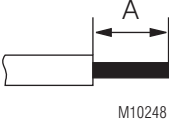
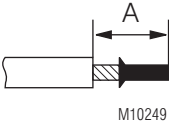
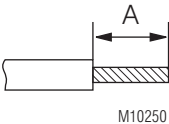
	Schraubklemmen, nicht abnehmbar Screw terminals, fixed Bornes à vis, fixes	Schraubklemmen, abnehmbar Screw terminals, pluggable Bornes à vis, amovibles	Federkraftklemmen, abnehmbar Cage clamp terminals, pluggable Bornes ressorts, amovibles	
		 PS	 PC	
	∅ 4 mm / PZ 1 0,8 Nm 7 LB. IN	∅ 4 mm / PZ 1 0,8 Nm 7 LB. IN	DIN 5264-A; 0,5 x 3	
 M10248	A = 8 mm 1 x 0,5 ... 4 mm ² 1 x AWG 20 to 12 2 x 0,5 ... 2,5 mm ² 2 x AWG 20 to 14	A = 8 mm 1 x 0,5 ... 2,5 mm ² 1 x AWG 20 to 14 2 x 0,5 ... 1,5 mm ² 2 x AWG 20 to 16	A = 10 ... 12 mm 1 x 0,5 ... 2,5 mm ² 1 x AWG 20 to 14	A = 12 mm 1 x 0,5 ... 4 mm ² 1 x AWG 20 to 12
 M10249	A = 8 mm 1 x 0,5 ... 2,5 mm ² 1 x AWG 20 to 14 2 x 0,5 ... 1,5 mm ² 2 x AWG 20 to 16	A = 8 mm 1 x 0,5 ... 2,5 mm ² 1 x AWG 20 to 14 2 x 0,5 ... 1 mm ² 2 x AWG 20 to 18	A = 10 ... 12 mm 1 x 0,5 ... 1,5 mm ² 1 x AWG 20 to 16	A = 12 mm 1 x 0,5 ... 2,5 mm ² 1 x AWG 20 to 14
 M10250	A = 8 mm 1 x 0,5 ... 4 mm ² 1 x AWG 20 to 12 2 x 0,5 ... 2,5 mm ² 2 x AWG 20 to 14	A = 8 mm 1 x 0,5 ... 2,5 mm ² 1 x AWG 20 to 14 2 x 0,5 ... 1,5 mm ² 2 x AWG 20 to 16	A = 10 ... 12 mm 1 x 0,5 ... 2,5 mm ² 1 x AWG 20 to 14	A = 12 mm 1 x 0,5 ... 4 mm ² 1 x AWG 20 to 12

DE	Maßbild (Maße in mm)
EN	Dimensions (dimensions in mm)
FR	Dimensions (dimensions en mm)

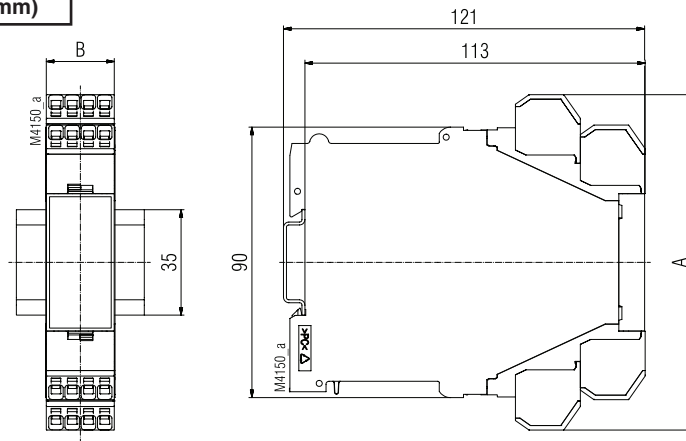

	A	B
LG 5925	90	22,5
LG 5925 PS	104	22,5
LG 5925 PC	111	22,5

DE	Geräteprogrammierung
EN	Setting
FR	Programmation de l'appareil

DE	Montage / Demontage der PS / PC-Klemmenblöcke
EN	Mounting / disassembly of the PS / PC-terminal blocks
FR	Montage / Démontage des borniers PS / PC

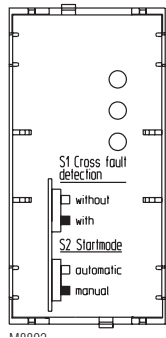
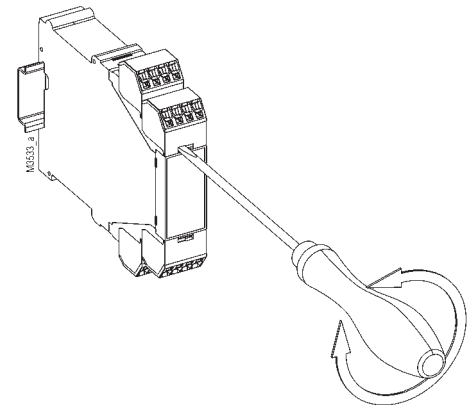
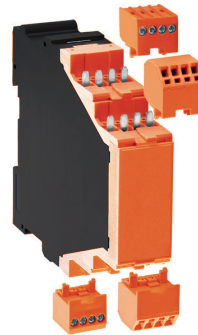
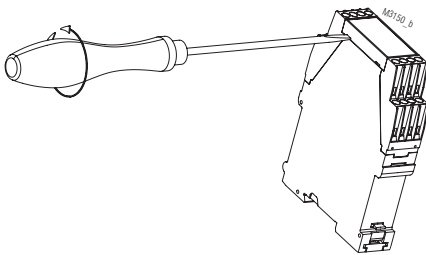

DE	S1 Querschlusserkennung <input type="checkbox"/> nicht sicher <input checked="" type="checkbox"/> sicher
FR	S1 Transversal <input type="checkbox"/> sans <input checked="" type="checkbox"/> avec
DE	S2 Start <input type="checkbox"/> Auto <input checked="" type="checkbox"/> Hand
FR	S2 Reset <input type="checkbox"/> Auto <input checked="" type="checkbox"/> Manu

DE	S1 darf nur bei unbestromtem Gerät betätigt werden! Die Schalterstellung zeigt den Lieferzustand. Die Variante LG 5925.54 mit Halbleiter-Meldeausgang hat immer Querschlusserkennung
EN	Disconnect unit before setting of S1 Drawing shows setting at the state of delivery The variant LG 5925.54 with semiconductor monitoring output has always cross fault detection
FR	Commutation de S1 uniquement hors tension. Appareil livré tel que sur le schéma. La variante LG 5925.54 avec sortie transistor de visualisation a toujours la reconnaissance de court-circuit transversal.

DE	Demontage der steckbaren Klemmenblöcke (Stecker) 1. Gerät spannungsfrei schalten. 2. Schraubendreher in die frontseitige Aussparung zwischen Stecker und Frontplatte hineinschieben. 3. Schraubendreher um seine Längsachse drehen. 4. Beachten Sie bitte, dass die Klemmenblöcke nur auf dem zugehörigen Steckplatz montiert werden.
EN	Removing the terminal blocks with cage clamp terminals 1. The unit has to be disconnected. 2. Insert a screwdriver in the side recess of the front plate. 3. Turn the screwdriver to the right and left. 4. Please note that the terminal blocks have to be mounted on the belonging plug in terminations.
FR	Démontage des borniers amovibles 1. Mise hors tension de l'appareil 2. Enfoncer un tourne-vis dans la fente entre la face avant et le bornier 3. Tourner le tourne-vis pour libérer le bornier 4. Tenir compte du fait que les borniers ne doivent être montés qu'à leur place appropriée

DE	Sicherheitstechnische Kenndaten
EN	Safety Related Data
FR	Données techniques sécuritaires

EN ISO 13849-1:		
Kategorie / Category:	4	
PL:	e	
MTTF _d :	216,7	a (year)
DC _{avg} :	99,0	%
d _{op} :	365	d/a (days/year)
h _{op} :	24	h/d (hours/day)
t _{cycle} :	3600	s/cycle
	≥ 1	/h (hour)

IEC/EN 62061 IEC/EN 61508 IEC/EN 61511:		
SIL CL:	3	IEC/EN 62061
SIL	3	IEC/EN 61508, IEC/EN 61511
HFT ^{*)} :	1	
DC:	99,0	%
PFH _D :	1,1E-10	h ⁻¹
PFD _{AVG} :	8,2E-05	(Low Demand Mode)
T _i :	20	a (year)
*) HFT = Hardware-Fehlertoleranz Hardware failure tolerance Tolérance défauts Hardware		

Anforderung seitens der Sicherheitsfunktion an das Gerät im High Demand Mode Demand to our device based on the evaluated necessary safety level of the application at High Demand Mode Consigne résultant de la fonction sécuritaire de l'appareil au High Demande Mode		Intervall für zyklische Überprüfung der Sicherheitsfunktion Intervall for cyclic test of the safety function Interval du contrôle cyclique de la fonction sécuritaire
nach, acc. to, selon EN ISO 13849-1	PL e with Cat. 3 or Cat. 4	einmal pro Monat once per month mensuel
	PL d with Cat. 3	einmal pro Jahr once per year annuel
nach, acc. to, selon IEC/EN 62061, IEC/EN 61508	SIL CL 3, SIL 3 with HFT = 1	einmal pro Monat once per month mensuel
	SIL CL 2, SIL 2 with HFT = 1	einmal pro Jahr once per year annuel



DE	Die angeführten Kenndaten gelten für die Standardtype. Sicherheitstechnische Kenndaten für andere Geräteausführungen erhalten Sie auf Anfrage. Die sicherheitstechnischen Kenndaten der kompletten Anlage müssen vom Anwender bestimmt werden.
EN	The values stated above are valid for the standard type. Safety data for other variants are available on request. The safety relevant data of the complete system has to be determined by the manufacturer of the system.
FR	Les valeurs données sont valables pour les produits standards. Les valeurs techniques sécuritaires pour d'autres produits spéciaux sont disponibles sur simple demande. Les données techniques sécuritaires de l'installation complète doivent être définies par l'utilisateur.

DE	EG-Konformitätserklärung
EN	CE-Declaration of Conformity
FR	Déclaration de conformité européenne

EG - Konformitätserklärung
Declaration of Conformity
Déclaration de conformité européenne



Hersteller: E. Dold & Söhne GmbH & Co. KG
Manufacturer: / Fabricant:
Anschrift: Bregstraße 18
Address: / Adresse: 78120 Furtwangen
Germany

Produktbezeichnung:	Not-Aus-Modul	LG5925.kkccc	mit:	kk = 02, 03, 04, 48, 54
<i>Product description:</i>	<i>Emergency-stop-module</i>	LG5925.kkttccc	<i>with:</i>	kk = 02, 04, 48 (für / for / pour /900, /920)
<i>Désignation du produit:</i>	<i>Module arrêt d'urgence</i>	LG5925.kktt/900ccc	<i>avec:</i>	tt = PS, PC
		LG5925.kk/920ccc		optional ccc = /60 .. /69

Das bezeichnete Produkt stimmt mit den Vorschriften folgender europäischer Richtlinien überein:
The indicated product is in conformance with the regulations of the following european directives:
Le produit désigné est conforme aux instructions des directives européennes:

Maschinenrichtlinie:	2006/42/EG	EU-Abl. L157/24, 09.06.2006
<i>Machinery directive: / Directives Machines:</i>		
EMV - Richtlinie:	2014/30/EU	EU-Abl. L96/79, 29.03.2014
<i>EMC - Directive: / Directives- CEM::</i>		
RoHS - Richtlinie	2011/65/EU	EU-Abl. L174/88, 01.07.2011
<i>RoHS -Directive: / Directives - RoHS:</i>		

Prüfgrundsätze:	EN ISO 13849-1:2015	EN 50178:1997
<i>Basis of Testing:</i>	EN 62061:2015 + A1:2013 + A2:2015	EN 61508 Parts 1-7:2010
<i>Lignes de contrôle:</i>	EN 50156-2:2015	
	EN 61000-6-1:2007	EN 61000-6-2:2005 + AC:2005
	EN 61000-6-3:2007 + A1:2011 + AC:2012	EN 61000-6-4:2007 + A1:2011
	EN 61326-3-1:2017	EN 55011:2009 + A1:2010
	EN 60947-5-1:2005 + A1:2009	

Die Übereinstimmung eines Baumusters des bezeichneten Produktes mit der oben genannten Maschinenrichtlinie wurde bescheinigt durch:

Consistency of a production sample with the marked product in accordance to the above machiney directive has been certified by:
La conformité d'un échantillon du produit désigné aux directives machines susmentionnées a été certifiée par:

Benannte Stelle:	TÜV Rheinland Industrie Service GmbH
<i>Certification office: / l'organisme notifié:</i>	Am Grauen Stein, 51105 Köln
Nummer der benannten Stelle:	0035
<i>Number of certification office: / Numéro de l'organisme notifié:</i>	
Nummer der Bescheinigung:	01/205/5197.03/21
<i>Certification number: / Numéro de certificat:</i>	
Ausstelldatum :	24.03.2021
<i>Date of issue: / Date de délivrance:</i>	

Für die Zusammenstellung der technischen Unterlagen ist bevollmächtigt:

*For the compilation of technical documents is authorized:
Pour la composition des documents techniques est autorisé:*

Gamal Hagar, Entwicklungsleiter / R&D Manager

Rechtsverbindliche Unterschrift:

*Signature of authorized person:
Signature du PDG :*

Christian Dold, Produktmanagment

Ort, Datum : Furtwangen, 10.06.2021
Place, Date: / Lieu, date:

Diese Original - Erklärung bescheinigt die Übereinstimmung mit den genannten Richtlinien, beinhaltet jedoch keine Zusicherung von Eigenschaften. Die Sicherheitshinweise der Produktdokumentation sind zu beachten.

This original declaration confirms the conformity of the mentioned directives but does not comprise any guarantee of the product characteristics. The safety directives of the product documentation are to be considered.

Cette déclaration originale certifie la conformité des directives nommées mais ne comprend aucune garantie des caractéristiques du produit. Les directives de sécurité de la documentation du produit sont à considérer.

DE	UK-Konformitätserklärung
EN	UK-Declaration of Conformity
FR	Déclaration de conformité UK

UK Declaration of Conformity



Manufacturer: E. Dold & Söhne GmbH & Co. KG

Address: Bregstraße 18
78120 Furtwangen
Germany

Product description: Emergency Stop Module

LG5925.kkccc mit: kk = 02, 03, 04, 48, 54
LG5925.kkttccc kk = 02, 04, 48 (für / for / pour
LG5925.kk/900ccc /900, /920)
LG5925.kktt/900ccc tt = PS, PC
LG5925.kk/920ccc optional ccc = /60 .. /69

The indicated product is in conformance with the regulations of the following British regulations:

Supply of Machinery (Safety) Regulations: S.I. 2008 No. 1597

Electromagnetic Compatibility Regulations: S.I. 2016 No. 1091

RoHS Regulations: S.I. 2012 No. 3032

Designated standards:

EN ISO 13849-1:2015	EN 50178:1997
EN 62061:2005 + AC:2010 + A1:2013 + A2:2015	EN 61508 Parts 1-7:2010
EN 50156-2:2015	
EN 61000-6-1:2007	EN 61000-6-2:2005
EN 61000-6-3:2007 + A1:2011	EN 61000-6-4:2007 + A1:2011
EN 61000-6-7:2015	EN 55011:2016 + A1:2017
EN 61326-1:2013	EN 61326-3-1:2017

Consistency of a production sample with the marked product in accordance to the above machinery directive has been certified by:

Certification office: TÜV Rheinland UK Ltd., Friars Gate(Third Floor),
1011 Stratford Road, Shirley, Solihull B90 4BN, United Kingdom
2571

Number of certification office:

Certification number: 01/205U/5107.00/22

Date of issue: 2022-07-28

For the compilation of technical documents is authorized: **Signature of authorized person:**

Dold Industries Ltd

11 Hamberts Rd. Blackall Ind. Estate
South Woodham Ferrers
GB - Essex, CM3 5UW

Christian Dold - Productmanagement

Place, Date : Furtwangen, 2022-08-23

This original declaration confirms the conformity of the mentioned directives but does not comprise any guarantee of the product characteristics. The safety directives of the product documentation are to be considered.



